

**REPORT
ON
ANNUAL ENERGY AUDIT
FOR
JAWAHARLAL NEHRU PORT TRUST
SHEVA, URAN**



**PREPARED
BY**



**INTEGRATED SOLUTIONS FOR
ENERGY SAVINGS | PERFORMANCE IMPROVEMENT | COMPLIANCE
JUNE 2022**

Contents

Preface.....	5
Acknowledgement.....	6
1 Executive Summary.....	7
2 Summary of Critical Analysis.....	9
3 Background.....	10
3.1 Extant Regulations and role of BEE	10
3.2 Purpose of Audit and accounting Report.....	10
3.3 Period of energy Auditing and accounting.....	10
4 Introduction of DISCOMs (DC).....	11
4.1 Name and Address of Designated Consumer	11
4.2 Name and contact details of Energy manager and Authorized signatory of DC (Nodal Officer).....	11
4.3 Summary profile of DCs.....	11
4.3.1 Summary of Power distribution Infrastructure.....	13
5 Energy Analysis.....	14
5.1.1 Energy accounts for previous year.....	14
5.1.2 Electricity Consumption.....	14
5.1.3 Electricity Losses.....	15
5.2 Performance Assessment & Observations.....	25
5.2.1 Power Supply and Distribution	25
5.2.2 Transformer	25
5.2.3 Power Quality Analysis.....	27
5.2.1 Harmonics Analysis	53
5.3 Energy Conservation measures already taken and proposed for future	78
5.3.1 Proposed energy conservation measures	78
5.4 Inclusion and Exclusions.....	78
6 Energy Accounting Major Observations.....	78
7 Annexures.....	80
7.1 Introduction of verification Firm.....	80

7.2	Minutes of meeting with DISCOM team	81
7.3	Checklist Prepared by auditing Firm.....	82
7.4	Scope of Work and Methodology Objective	82
7.5	Infrastructure details.....	84
7.6	Electrical Distribution System	91
7.7	Power Purchase Details.....	95
7.8	Category of service details.....	96
7.9	List of documents verified with each parameter	96
7.10	List of parameters arrived through calculation	96

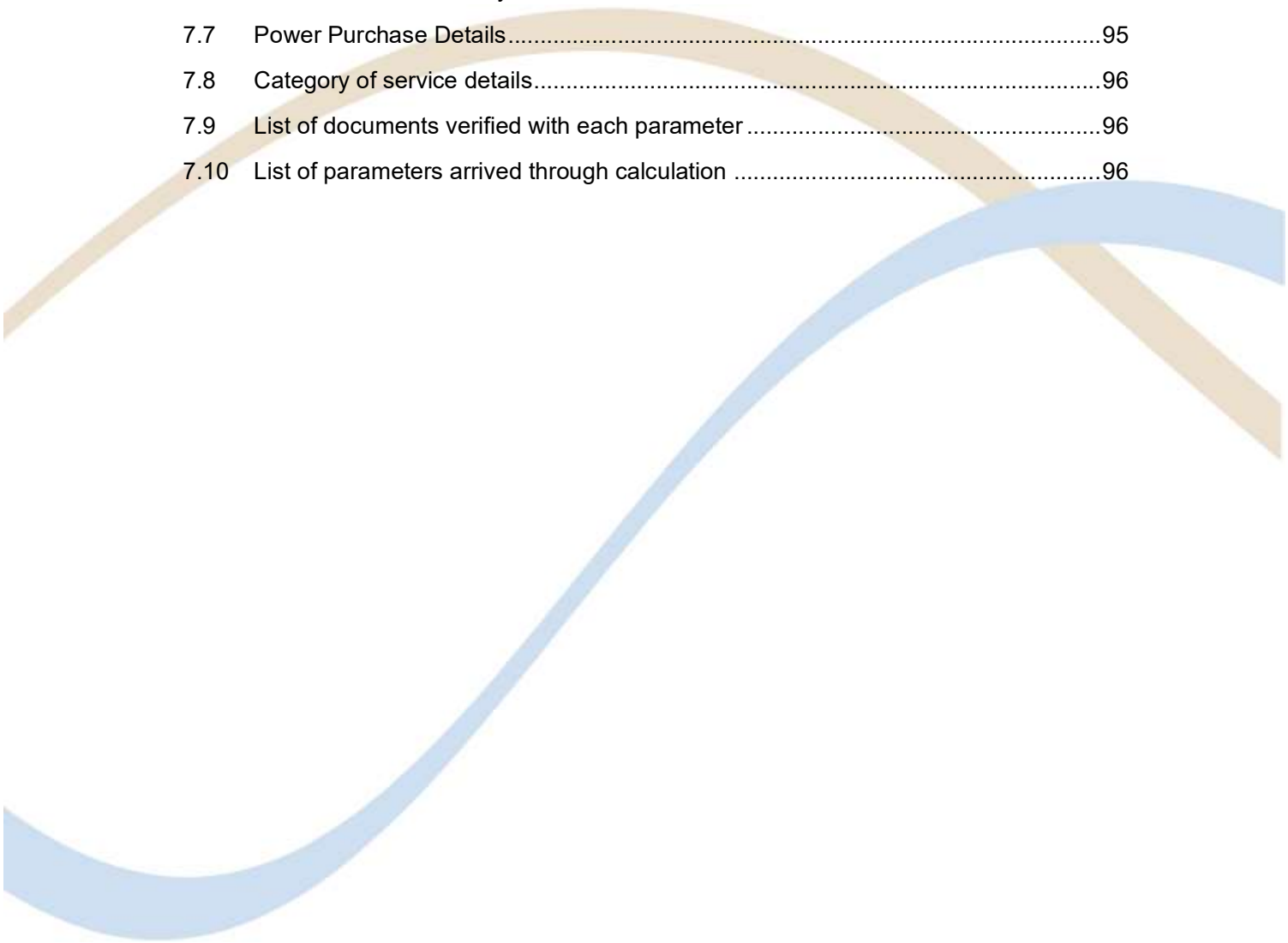

ABBREVIATIONS

Amp	Ampere
AC	Alternating Current
Avg.	Average
BEE	Bureau of Energy Efficiency
EE	Energy Efficiency
FG	Flue Gas
FRP	Fibre Reinforced Plastic
hr	Hour
kV	kilo Volt
kVA	kilo Volt Ampere
kVAr	kilo Volt Ampere Reactive
kW	kilo Watts
kWh	kilo Watt Hour
kVAh	Kilo volt amp hours
Kg	Kilogram
M	Meter
MD	Maximum Demand
MU	Millions of Units
MWh	Mega Watt Hour
NA	Not Applicable
No. s	Numbers
OEM	Original Equipment Manufacturer
PF	Power Factor
P-P	Phase to Phase
Ph-N	Phase to Neutral
SLD	Single Line Diagram
Temp.	Temperature
THD	Total Harmonic Distortion
V	Voltage
Y.	Year

Preface

M/s. Jawaharlal Nehru Port Trust- Special Economic Zone (SEZ), The proposed Special Economic Zone at Jawaharlal Nehru Port is the first-of-its-kind at a major port complex in the country and being developed on 277.38 hectares of land along the Panvel - Uran Road connecting the cargo terminals to state highways.

The site is around 15 km from Navi Mumbai and around 40 km from Mumbai city. There are three villages and one township within the catchment area; the JNPT Township, Belpada village near the approach road from Panvel, the Jashkar Village and Karal, Sonari, Savarkhar village near the area where the NH 4B and SH 54 meet. Another road linking the port to Panvel is being constructed. Land: Land is owned by JNPT. Lease hold land free from any legal litigations. Lease of land for 60 years and eligible for further extensions as per Port land policy guidelines.

The present energy audit is for verification of energy accounting and identification of energy optimization measures at Jawaharlal Nehru Port Trust- Special Economic Zone (SEZ).

Acknowledgement

An Energy Audit is collaboration between consultant and consumer in premises to account & contain electrical Power consuming Equipment's. The contribution of facility's team is equally important in this effort. We sincerely acknowledge the contribution of the following dignitaries and site personnel because of whom the audit could progress smoothly.

- Mr. Anil Chopade- - Manager Utility Services
- Mr. Milind Aigalikar - Deputy Manager Utility Services
- Mr. B.D. Sinkar - Assistant manager Utility Services

We are also thankful to the other staff members who were actively involved while collecting the data and conducting the field studies.

The Consultants team of ENCOSYM Solutions Pvt. Ltd. Was ably represented by

- Mr. Abhay Athalye - BEE Certified Energy Auditor, Director
- Mr. Babu Amritkar - Director
- Mr. Shailesh Joshi - Director
- Mr. Atul Joshi - BEE Accredited Energy Auditor **(AEA-0037)**
- Mr. Umesh Phatakare - BEE Certified Energy Manager **(EA-31077)**
- Mr. Ratnadeep Bhalerao - Sr. Engineer – Energy Audit
- Mr. Mukesh Mhasde - Engineer- Energy Audit



Mr. Atul Joshi
BEE Accredited Energy Auditor
(AEA-0037)



1 Executive Summary

- In the energy accounting of JNPT-SEZ, the transformer losses & distribution losses are calculated based on the annual electricity consumption, the details are as under,

Description	Unit	Aug-21	Sep-21	Oct-21	Nov-21
Main Transformer TR-1 & TR-2 (50 MVA X 2 nos.)	%	23.0%	27.8%	22.7%	12.9%
ES1-TR 1 & TR 2-(8 MVA X 2 nos.)	%	NA	8.5%	6.9%	6.2%
ES2-TR-1 & TR-2- (8MVA X 2nos.)	%	NA	8.5%	6.9%	6.2%
ES2-TR-3 & TR-4- (8 MVA X 2nos.)	%	NA	8.5%	6.9%	6.2%
ES2 TR-200kVA	%	NA	0.1%	0.1%	0.1%
Transformer 500 kVA	%	NA	0.2%	0.1%	0.1%
ES3 Street Light TR-315kVA Transformer Losses	%	NA	NA	NA	0.1%
All Transformer Losses	%	23.0%	53.5%	43.7%	31.7%
Distribution line & service connection Losses	%	NA	7.2%	6.2%	9.8%
Technical Losses @ commissioning phase	%	77.0%	NA	NA	NA
Total Losses	%	100.0%	60.7%	49.9%	41.5%

Description	Unit	Dec-21	Jan-22	Feb-22	Mar-22
Main Transformer TR-1 & TR-2 (50 MVA X 2 nos.)	%	8.0%	7.5%	6.6%	5.5%
ES1-TR 1 & TR 2-(8 MVA X 2 nos.)	%	4.9%	4.5%	4.0%	3.4%
ES2-TR-1 & TR-2- (8MVA X 2nos.)	%	4.9%	4.5%	4.0%	3.4%
ES2-TR-3 & TR-4- (8 MVA X 2nos.)	%	4.9%	4.5%	4.0%	3.4%
ES2 TR-200kVA	%	0.0%	0.0%	0.0%	0.0%
Transformer 500 kVA	%	0.1%	0.1%	0.1%	0.1%
ES3 Street Light TR-315kVA Transformer Losses	%	0.1%	0.1%	0.1%	0.1%
All Transformer Losses	%	22.8%	21.3%	18.7%	15.8%
Distribution line & service connection Losses	%	7.7%	5.9%	7.3%	1.8%
Technical Losses @ commissioning phase	%	NA	NA	NA	NA
Total Losses	%	30.5%	27.2%	26.0%	17.6%

Observations and remarks:

- Transformer Losses are higher with the lower loading of the transformers.
- As in the month of September 2021 & March 2022 the overall losses are around **~60.7%** & **17.6%** respectively.
- As the operation of industries increased at the JNPT-SEZ the overall losses have been reduced.
- Annual consumer consumption and T&D losses for year 2021-2022, are represented in the below mentioned chart.

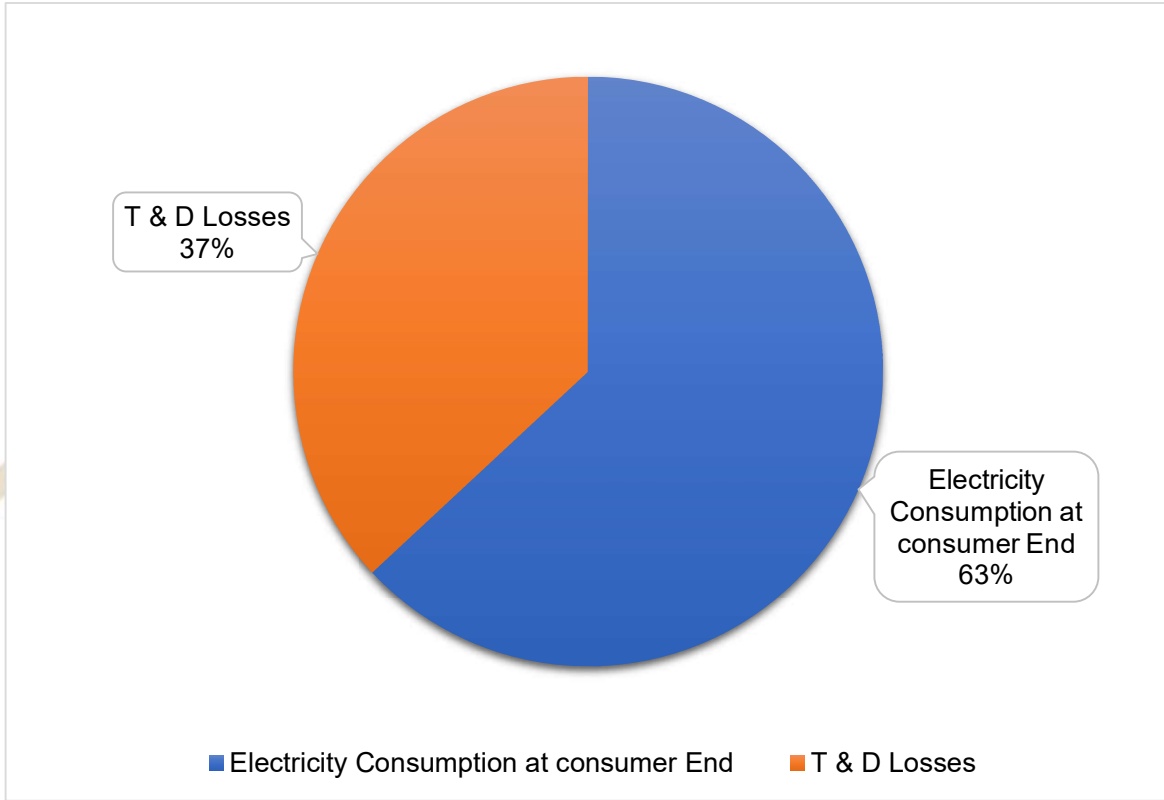

2 Summary of Critical Analysis

The overall the T & D losses are reduced over the time interval, as increase in the operation of industries in JNPT-SEZ, the major observations are as under,

1. Referring to the BEE notification no. **No. 18/1/BEE/DISCOM/2021**, The software has not been developed to create monthly, quarterly and yearly energy accounting reports. The electricity distribution company shall establish an information technology enabled system to create energy accounting reports without any manual interference: Provided that such system may be established within a period of three years from the date of the commencement of these regulations in case of urban.
2. Till the establishment IT enabled system, the energy accounting at transformer level need to be done for evaluation of losses, i.e., Transmission & Distribution losses and transformer losses. To evaluate the exact losses within the distribution system, the data accounting at 33kV, 11kV and Feeder wise need to be done on the propriety basis.
For the recording and monitoring of electrical power at ES1 & ES2 subs station, it is suggested to install desired size CTs at all electrical panels, in consultation with OEM.
3. At the consumer end the power factor need to be unity to optimize the distribution losses.
4. At the station level maintain the near to unity power factor to optimize the losses, i.e., at the time of annual energy audit visit the power factor at ES-2 I/C-1 is around 0.238 leading with load of 25.71kWh/ 96.06kVAh, which accounts for losses around 70kWh with unity power factor.
At present the capacitor bank is not in operation. So, it is suggested to install the passive filters in consultation with OEM, to optimize the leading power factor to near unit.

3 Background

3.1 Extant Regulations and role of BEE

Bureau of Energy Efficiency (BEE) through Ministry of Power, Government of India issued regulations for Conduct of Mandatory Annual Energy Audit and Periodic Energy Accounting in DISCOMs. As per the regulation, BEE notification no. **No. 18/1/BEE/DISCOM/2021** dated October 7, 2021, all Electricity Distribution Companies are mandated to conduct annual energy audit and periodic energy accounting on quarterly basis.

Owing to the impact of energy auditing on the entire distribution and retail supply business and absence of an existing framework with dedicated focus on the same, it was imperative to develop a set of comprehensive guidelines that all Distribution utilities across India can follow and adhere to. Accordingly, Regulations on Manner and Intervals for Conduct of Energy Audit and Accounting in Electricity Distribution Companies has been framed.

3.2 Purpose of Audit and accounting Report

Energy Accounting means accounting of all energy inflows at various voltage levels in the distribution periphery of the network, including renewable energy generation and open access consumers, and energy consumption by the end consumers. Energy accounting and a consequent annual energy audit would help to identify areas of high loss and pilferage, and thereafter focus efforts to take corrective action.

3.3 Period of energy Auditing and accounting

These Regulations for Energy audit in Electricity Distribution Companies provides broad framework for conduct of Annual Energy Audit though and Quarterly Periodic Energy Accounting with necessary Pre-requisites and reporting requirements to be met.

The period of Energy Accounting in this report considered to by FY 2021-2022 i.e. from 1st April 2021 to 31st March 2022.

At JNPT-SEZ the field visit for the purpose of annual energy audit has been conducted on 25th May 2022 & 30th May 2022. While all the requisite data verification has been done by the 20th June 2022.

4 Introduction of DISCOMs (DC)

4.1 Name and Address of Designated Consumer

1	Name of the DISCOM			Jawaharlal Nehru Port Trust SEZ		
2	i) Year of Establishment			2014 (Notification of SEZ)		
	ii) Government/Public/Private			Government		
3	DISCOM's Contact details & Address					
i	City/Town/Village			Savarkahar, Karal, Sonari and Jaskhar		
ii	District			Raigad		
iii	State		Pin		400707	
iv	Telephone		Fax			
	022 67814196					
4	Registered Office					
i	Company's Chief Executive Name			Mr. Sanjay Sethi, IAS		
ii	Designation			Chairman		
iii	Address					
	Administrative Building, Sheva, Uran, Navi Mumbai 400707					
iv	City/Town/Village		P.O.			
	Navi Mumbai					
v	District			Raigad		
vi	State		Pin		400707	
vii	Telephone		Fax			
	022 67814100					

4.2 Name and contact details of Energy manager and Authorized signatory of DC (Nodal Officer)

1	Nodal Officer Details					
i	Nodal Officer Name (Designated at DISCOM's)			Mr. Anil Chopade		
ii	Designation			Manager (US)		
iii	Address					
	Administrative Building, Sheva, Uran, Navi Mumbai 400707					
iv	City/Town/Village		P.O.			
	Navi Mumbai					
v	District			Raigad		
vi	State		Pin		400707	
vii	Telephone		Fax			
	022 67814196					
2	Energy Manager Details					
i	Name			Mr. Umesh Phatakare		
ii	Designation		Whether EA or EM		EM	
	Energy Manager					
iii	EA/EM Registration No.			EA-31077		
iv	Telephone			Fax		
v	Mobile		E-mail ID		umesh.phatakare@encosym.com	
	8424841657					

4.3 Summary profile of DCs

M/s. Jawaharlal Nehru Port Trust- Special Economic Zone (SEZ), The proposed Special Economic Zone at Jawaharlal Nehru Port is the first-of-its-kind at a major port complex in the country and being developed on 277.38 hectares of land along the Panvel – Uran Road connecting the cargo terminals to state highways.

The site is around 15 km from Navi Mumbai and around 40 km from Mumbai city. There are three villages and one township within the catchment area; the JNPT Township, Belpada village near the approach road from Panvel, the Jashkar Village and Karal, Sonari, Savarkhar village near the area where the NH 4B and SH 54 meet. Another road linking the port to Panvel

is being constructed. Land is owned by JNPT. Lease hold land free from any legal litigations. Lease of land for 60 years and eligible for further extensions as per Port land policy guidelines.

JNPT SEZ procures power through competitive bidding process as per standard guidelines of MoP, Gol on DEEP portal. Presently the power is procured on short term open access from Birla Carbon India Pvt Ltd (Generator), through Manikaran Power Limited (Trader) at 220KV T<>D grid interface, which is further step down to 33Kv by 2x50MVA power transformers.

The details of transaction parties to grid are as follows,

Details of Transaction Party's to Grid		
	Injecting Entity	Drawee Entity
Name of Entity	BIRLA CARBON INDIA PVT LTD	Jawaharlal Nehru Port Trust SEZ
12status of Entity*	CPP	
Utility in which it is embedded	MSEDCL	MSETCL

Details of Injecting/Drawee Connectivity with Intra-State Transmission System/Distribution			
		Injecting Entity	Drawee Entity
Name of Sub Station	Transmission	100 KV Patalganga Substation	220 KV JNPT SEZ Substation
	Distribution		
Voltage Level	Transmission	100/110 kV	220 kV
	Distribution		
Name of Licensee (Owner of S/S)		MSEDCL	MSETCL

The major assets within the JNPT SEZ premises are as under,

- Transformer

Transformers Detail	Quantity	Steps(kV)
50 MVA	2	220/33
8 MVA	8	33/11
500KVA	1	33/0.440
200 KVA	2	11/0.440
100 KVA	1	11/0.440
315 KVA	1	11/0.440

- Present Consumer Details

Substation Transformer	RMU	Consumer Name
ES-1-TR1/TR2, 8MVA	RMU-3	M/s Simosis International
	RMU-11	M/s Krish Food Industry (India)
	RMU-5	M/s Rudra Flexipack LLP
	RMU-6 A	M/s R K Sweets Mars Pvt Ltd

Substation Transformer	RMU	Consumer Name
ES2-TR-1/TR-2, 8MVA	RMU-24	M/s Sadanand Engineering Works
	RMU-24	M/s Piyush Enterprises
	RMU-24	Admin Building
ES2-TR-3/TR-4, 8 MVA	RMU-28	M/s Nhava Sheva Business Parks Pvt Ltd
ES-2 TR, 200kVA	-	Streetlight
ES-1 TR, 200kVA	-	Station Transformer-01
	-	M/s Sarveshwar Logistics Services Pvt Ltd
Transformer 500 kVA	-	Station Transformer- 500kVA
ES-3-TR 100 KVA	-	Streetlight

4.3.1 Summary of Power distribution Infrastructure

For details refer annexure 7.5 and for SLD refer annexure 7.6

5 Energy Analysis

5.1.1 Energy accounts for previous year

DISCOM is charged from August 2021 and the operation of some of the industries started from September 2021. DISCOM is carrying out the energy audit for the first time, the details of energy accounting for present year is provided in section 5.1.2.

5.1.2 Electricity Consumption

- Monthly electrical power consumption at the premises is provided in table below,

Description	Unit	Aug-21	Sep-21	Oct-21	Nov-21	Dec-21	Jan-22	Feb-22	Mar-22
Monthly Energy Balance									
Electricity Input at main meter (220kV)	MU	0.096157	0.113807	0.143957	0.155865	0.204699	0.212305	0.225334	0.286102
Electricity Consumption at consumer End	MU	0.000000	0.044675	0.072177	0.091115	0.142174	0.154630	0.166685	0.235704
Electricity Consumption at Consumer End									
M/s Simosis International		NA	1004.0	2299.0	2023.0	2273.0	2679.0	2368.4	2846.4
M/s Krish Food Industry (India)		NA	1124.0	10891.0	27050.0	70323.0	69782.0	69115.0	82605.5
M/s Sarveshwar Logistics Services Pvt Ltd		NA	NA	1053	715	663	645.0	372.6	779.4
M/s Rudra Flexipack LLP		NA	NA	NA	NA	NA	1175.0	4668.4	2437.2
M/s R K Sweets Mars Pvt Ltd		NA	NA	NA	NA	832	2872.0	12072.4	42056.4
M/s Sadanand Engineering Works		NA	NA	NA	NA	NA	52.2	45.8	132.1
E-3 SS -Street Light		NA	NA	NA	85	142.0	1767.0	3551.5	2285.0
M/s Piyush Enterprises		NA	NA	344.0	844.0	642.0	602.0	398.0	836.0
M/s Nhava Sheva Business Parks Pvt Ltd		NA	16450.0	30005.0	33025.0	40345.0	47435.0	48637.5	56705.0
Admin Building		NA	2043.0	8476.2	9254.7	12298.0	9063.0	7331.0	11624.0
E1 & E2 SS-200kVA Transformer Street Light		NA	8.0	1200.0	1334.0	1088.0	2284.0	2724.0	4655.0
E1 & E2 SS-200kVA Station Transformer-01		NA	3490.0	3577.0	3169.0	3204.0	4997.0	4495.9	5009.1
Station Transformer- 500kVA		NA	20556.5	14332.0	13615.0	10364.4	11277.3	10904.2	23733.4

Note: Industries at JNPT SEZ has been started the industries operation from September 2021.

5.1.3 Electricity Losses

5.1.3.1 Overall Transmission and distribution losses.

- Electrical losses at the premises are provided in table below,

Description	Unit	Aug-21	Sep-21	Oct-21	Nov-21	Dec-21	Jan-22	Feb-22	Mar-22
Monthly Energy Balance									
Electricity Input at main meter (220kV)	MU	0.096157	0.113807	0.143957	0.155865	0.204699	0.212305	0.225334	0.286102
Electricity Consumption at consumer End	MU	0.000000	0.044675	0.072177	0.091115	0.142174	0.154630	0.166685	0.235704
T & D Losses	MU	0.096157	0.069132	0.071780	0.064750	0.062525	0.057675	0.058649	0.050398
	%	100%	61%	50%	42%	31%	27%	26%	18%
Quarterly Energy Balance									
Quarterly Input	MU		0.209964		0.504521			0.723741	
Electricity Consumption at consumer End	MU		0.044675		0.305466			0.557020	
T & D Losses	MU		0.165289		0.199055			0.166721	
	%		79%		39%			23%	
Annual Energy Balance									
Electricity Input at main meter (220kV)	MU					1.438226			
Electricity Consumption at consumer End	MU					0.907162			
T & D Losses	MU					0.531064			
	%					37%			

Observation:

- At JNPT SEZ, some of the industries has been started the operation from the month of September 2021 onwards.
- The cumulative consumption for the financial year 2021-2022 is 1.438226 MU and at the consumer end electricity consumption is 0.907162 MU.
- Transmission and distribution losses are higher at the second quarter, which around ~79%.
- Transmission and distribution losses has been reduced to value of ~23%, in the 4th quarter.

- The overall losses for the year 2021-2022 are ~37%.

5.1.3.2 Transformer

- The transformer losses are evaluated from the operation of transformer, average consumption for the respective period and with reference to the electrical distribution network.
- The details transformer wise losses are as under,

Description	Unit	Aug-21	Sep-21	Oct-21	Nov-21	Dec-21	Jan-22	Feb-22	Mar-22
50 MVA Transformer Losses-TR-1									
Electricity Input at main meter (220kV)	MU	0.0480785	0.0569035	0.0719785	0.020782	0.114301	0.212305	0.225334	0.286102
Operation period	Days	21	30	31	8	22	30	28	30
Average Electricity Consumption	MU/Day	0.0022895	0.001896783	0.002321887	0.00259775	0.0051955	0.007076833	0.008047643	0.009536733
Transformer Loading	kW/hr	95.4	79.0	96.7	108.2	216.5	294.9	335.3	397.4
Transformer Loading @ Unity PF	%	0.2%	0.2%	0.2%	0.2%	0.4%	0.6%	0.7%	0.8%
Transformer No Load Losses	kW					21.98			
Transformer Load Losses	kW					146.63			
Actual transformer Losses	kW	21.98	21.98	21.98	21.98	21.98	21.99	21.99	21.99
	MU	0.011078	0.015826	0.016354	0.004220	0.011607	0.015829	0.014775	0.015832
	%	11.5%	13.9%	11.4%	10.2%	8.0%	7.5%	6.6%	5.5%
50 MVA Transformer Losses-TR-2									
Electricity Input at main meter (220kV)	MU	0.0480785	0.0569035	0.0719785	0.020782		0	0	0
Operation period	Days	21	30	31	8		0	0	0
Average Electricity Consumption	MU/Day	0.0022895	0.001896783	0.002321887	0.00259775		0	0	0
Transformer Loading	kW/hr	95.4	79.0	96.7	108.2		0	0	0
Transformer Loading	%	0.2%	0.2%	0.2%	0.2%		0	0	0
Transformer No Load Losses	kW					21.98			
Transformer Load Losses	kW					146.63			
Actual transformer Losses	kW	21.98	21.98	21.98	21.98	0	0	0	0

Description	Unit	Aug-21	Sep-21	Oct-21	Nov-21	Dec-21	Jan-22	Feb-22	Mar-22
	MU	0.011078	0.015826	0.016354	0.004220	0	0	0	0
	%	11.5%	13.9%	11.4%	2.7%	0.0%	0.0%	0.0%	0.0%
Total 50 MVA Transformers Losses		23.0%	27.8%	22.7%	12.9%	8.0%	7.5%	6.6%	5.5%

Note: Both the 50 MVA transformers were operating till the November 8, 2021 & while other six substation transformer are operating for the financial year 2021-2022.

Description	Unit	Aug-21	Sep-21	Oct-21	Nov-21	Dec-21	Jan-22	Feb-22	Mar-22
ES1 TR 1-8 MVA Transformer Losses									
M/s Simosis International		NA	502	1150	1012	1137	1340	1184	1423
M/s Krish Food Industry (India)		NA	562	5446	13525	35162	34891	34558	41303
M/s Rudra Flexipack LLP		NA	NA	NA	NA	NA	588	2334	1219
M/s R K Sweets Mars Pvt Ltd		NA	NA	NA	NA	416	1436	6036	21028
Total Load	kWh	NA	1064	6595	14537	36714	38254	44112	64973
Operation Period	Days	NA	30	31	30	31	30	28	30
Average Electricity Consumption per Hour	kWh	NA	1.5	8.9	20.2	49.3	53.1	65.6	90.2
Transformer Loading @ 0.95 power factor	%	NA	0.0%	0.1%	0.3%	0.6%	0.7%	0.9%	1.2%
8 MVA Transformer No Load Losses	kW				6.7				
8 MVA Transformer Load Losses	kW				58.0				
Actual transformer Losses	kW	NA	6.70	6.70	6.70	6.70	6.70	6.70	6.71
	MU	NA	0.004824	0.004985	0.004824	0.004987	0.004826	0.004505	0.004830
Actual transformer Losses @ total load	%	NA	4.24%	3.46%	3.10%	2.44%	2.27%	2.00%	1.69%
ES1 TR 2-8 MVA Transformer Losses									
M/s Simosis International		NA	502	1150	1012	1137	1340	1184	1423
M/s Krish Food Industry (India)		NA	562	5446	13525	35162	34891	34558	41303
M/s Rudra Flexipack LLP		NA	NA	NA	NA	NA	588	2334	1219
M/s R K Sweets Mars Pvt Ltd		NA	NA	NA	NA	416	1436	6036	21028
Total Load	kWh	NA	1064	6595	14537	36714	38254	44112	64973



Ref: ENCOSYM_EA/FY23_001
Date: June 29, 2022

Annual Energy Audit Report
M/s JNPT-SEZ

Description	Unit	Aug-21	Sep-21	Oct-21	Nov-21	Dec-21	Jan-22	Feb-22	Mar-22
Operation Period	Days	NA	30	31	30	31	30	28	30
Average Electricity Consumption per Hour	kWh	NA	1.5	8.9	20.2	49.3	53.1	65.6	90.2
Transformer Loading @ 0.95 power factor	%	NA	0.0%	0.1%	0.3%	0.6%	0.7%	0.9%	1.2%
8 MVA Transformer No Load Losses	kW	6.7							
8 MVA Transformer Load Losses	kW	58.0							
Actual transformer Losses	kW	NA	6.70	6.70	6.70	6.70	6.70	6.70	6.71
	MU	NA	0.004824	0.004985	0.004824	0.004987	0.004826	0.004505	0.004830
Actual transformer Losses @ total load	%	NA	4.24%	3.46%	3.10%	2.44%	2.27%	2.00%	1.69%
ES1 TR 1 & 2-8 MVA Transformer Losses		NA	8.48%	6.93%	6.19%	4.87%	4.55%	4.00%	3.38%
ES2 TR1 -8 MVA Transformer Losses									
M/s Sadanand Engineering Works		NA	NA	NA	NA	NA	26	23	66
M/s Piyush Enterprises		NA	NA	172	422	321	301	199	418
Admin Building		NA	1022	4238	4627	6149	4532	3666	5812
315KVA Transformer Street Light		NA	NA	NA	85	142	1767	3551.5	2285
Total Load	kWh	NA	1021.5	4410.11	5134.36	6612	6625.595	7438.92	8581.065
Operation Period	Days	NA	30	31	30	31	30	28	30
Average Electricity Consumption per Hour	kWh	NA	1.4	5.9	7.1	8.9	9.2	11.1	11.9
Transformer Loading @ 0.27 power factor	%	NA	0.07%	0.27%	0.33%	0.41%	0.43%	0.51%	0.55%
8 MVA Transformer No Load Losses	kW	6.7							
8 MVA Transformer Load Losses	kW	58.0							
Actual transformer Losses	kW	NA	6.70	6.70	6.70	6.70	6.70	6.70	6.70
	MU	NA	0.004824	0.004985	0.004824	0.004986	0.004825	0.004503	0.004825
Actual transformer Losses @ total load	%	NA	4.24%	3.46%	3.10%	2.44%	2.27%	2.00%	1.69%
ES2 TR 2-8 MVA Transformer Losses									
M/s Sadanand Engineering Works		NA	NA	NA	NA	NA	26	23	66
M/s Piyush Enterprises		NA	NA	172	422	321	301	199	418
Admin Building		NA	1022	4238	4627	6149	4532	3666	5812



Ref: ENCOSYM_EA/FY23_001
Date: June 29, 2022

Annual Energy Audit Report
M/s JNPT-SEZ

Description	Unit	Aug-21	Sep-21	Oct-21	Nov-21	Dec-21	Jan-22	Feb-22	Mar-22	
315KVA Transformer Street Light		NA	NA	NA	85	142	1767	3551.5	2285	
Total Load	kWh	NA	1022	4410	5134	6612	6626	7439	8581	
Operation Period	Days	NA	30	31	30	31	30	28	30	
Average Electricity Consumption per Hour	kWh	NA	1.4	5.9	7.1	8.9	9.2	11.1	11.9	
Transformer Loading @ 0.27 power factor	%	NA	0.07%	0.27%	0.33%	0.41%	0.43%	0.51%	0.55%	
8 MVA Transformer No Load Losses	kW	6.7								
8 MVA Transformer Load Losses	kW	58.0								
Actual transformer Losses	kW	NA	6.70	6.70	6.70	6.70	6.70	6.70	6.70	
	MU	NA	0.004824	0.004985	0.004824	0.004986	0.004825	0.004503	0.004825	
Actual transformer Losses @ total load	%	NA	4.24%	3.46%	3.10%	2.44%	2.27%	2.00%	1.69%	
ES2 TR 1& 2 -8 MVA Transformer Losses	%	NA	8.48%	6.93%	6.19%	4.87%	4.55%	4.00%	3.37%	
ES2 TR-3 -8 MVA Transformer Losses										
M/s Nhava Sheva Business Parks Pvt Ltd		NA	8225	15003	16513	20173	23718	24319	28353	
Total Load	kWh	NA	8225	15003	16513	20173	23718	24319	28353	
Operation Period	Days	NA	30	31	30	31	30	28	30	
Average Electricity Consumption per Hour	kWh	NA	11.4	20.2	22.9	27.1	32.9	36.2	39.4	
Transformer Loading @ 0.99 power factor	%	NA	0.14%	0.25%	0.29%	0.34%	0.42%	0.46%	0.50%	
8 MVA Transformer No Load Losses	kW	6.7								
8 MVA Transformer Load Losses	kW	58.0								
Actual transformer Losses	kW	NA	6.70	6.70	6.70	6.70	6.70	6.70	6.70	
	MU	NA	0.004824	0.004985	0.004824	0.004985	0.004825	0.004503	0.004825	
Actual transformer Losses @ total load	%	NA	4.24%	3.46%	3.10%	2.44%	2.27%	2.00%	1.69%	
ES2 TR-4 -8 MVA Transformer Losses										
M/s Nhava Sheva Business Parks Pvt Ltd		NA	8225	15003	16513	20173	23718	24319	28353	
Operation period		NA	30	31	8	31	30	28	30	
Total Load	kWh	NA	8255.0	15033.5	16520.5	20203.5	23747.5	24346.8	28382.5	
Operation Period	Days	NA	30	31	30	31	30	28	30	



Ref: ENCOSYM_EA/FY23_001
Date: June 29, 2022

Annual Energy Audit Report
M/s JNPT-SEZ

Description	Unit	Aug-21	Sep-21	Oct-21	Nov-21	Dec-21	Jan-22	Feb-22	Mar-22
Average Electricity Consumption per Hour	kWh	NA	11.5	20.2	22.9	27.2	33.0	36.2	39.4
Transformer Loading @ 0.99 power factor	%	NA	0.14%	0.26%	0.29%	0.34%	0.42%	0.46%	0.50%
8 MVA Transformer No Load Losses	KW	6.7							
8 MVA Transformer Load Losses	KW	58.0							
Actual transformer Losses	KW	NA	6.70	6.70	6.70	6.70	6.70	6.70	6.70
Actual transformer Losses @ total load	MU	NA	0.004824	0.004985	0.004824	0.004985	0.004825	0.004503	0.004825
ES2 TR-3 & 4 -8 MVA Transformer Losses	%	NA	4.24%	3.46%	3.10%	2.44%	2.27%	2.00%	1.69%
ES1 TR-200kVA Transformer Losses	%	NA	8.48%	6.93%	6.19%	4.87%	4.55%	4.00%	3.37%
ES1 TR-200kVA Transformer Losses									
ES1 & ES2 SS-200kVA Station Transformer-01	NA	NA	3490	3577	3169	3204	4997	4495.9	5009.1
M/s Sarveshwar Logistics Services Pvt Ltd	NA	NA	NA	1063	715	663	645	372.6	779.4
Total Load	kWh	NA	3490.0	4630.0	3884.0	3867.0	5642.0	4868.5	5788.5
Operation Period	Days	NA	30	31	30	31	30	28	30
Average Electricity Consumption per Hour	kWh	NA	4.8	6.2	5.4	5.2	7.8	7.2	8.0
Transformer Loading @ 0.94 power factor	%	NA	0.06%	0.08%	0.07%	0.07%	0.10%	0.10%	0.11%
8 MVA Transformer No Load Losses	KW	0.275							
8 MVA Transformer Load Losses	KW	2.300							
Actual transformer Losses	KW	NA	0.28	0.28	0.28	0.28	0.28	0.28	0.28
Actual transformer Losses	MU	NA	0.000198	0.000205	0.000198	0.000205	0.000198	0.000185	0.000198
ES2 TR-200kVA Transformer Losses	%	NA	0.2%	0.1%	0.1%	0.1%	0.1%	0.1%	0.1%
ES2 TR-200kVA Transformer Losses									
ES1 & ES2 SS-200kVA Transformer Street Light	NA	NA	8	1200	1334	1088	2284	2724	4655
Total Load	kWh	NA	8.0	1200.0	1334.0	1088.0	2284.0	2724.0	4655.0
Operation Period	Days	NA	30	31	30	31	30	28	30
Average Electricity Consumption per Hour	kWh	NA	0.0	3.2	3.7	2.9	6.3	8.1	12.9
Transformer Loading @ 0.98 power factor	%	NA	0.00%	0.04%	0.05%	0.04%	0.08%	0.10%	0.16%
8 MVA Transformer No Load Losses	KW	0.3							



Description	Unit	Aug-21	Sep-21	Oct-21	Nov-21	Dec-21	Jan-22	Feb-22	Mar-22
8 MVA Transformer Load Losses	kW				2.300				
Actual transformer Losses	kW	NA	0.28	0.28	0.28	0.28	0.28	0.28	0.28
	MU	NA	0.000099	0.000102	0.000099	0.000102	0.000099	0.000092	0.000099
	%	NA	0.09%	0.07%	0.06%	0.05%	0.05%	0.04%	0.03%
Station TR-500kVA Transformer Losses									
Station Transformer- 500kVA		NA	20556.48	14332.025	13615.038	10364.366	11277.256	10904.19	23733.364
Total Load	kWh	NA	20556.5	14332.0	13615.0	10364.4	11277.3	10904.2	23733.4
Operation Period	Days	NA	30	31	30	31	30	28	30
Average Electricity Consumption per Hour	kWh	NA	28.6	19.3	18.9	13.9	15.7	16.2	33.0
Transformer Loading @ 0.98 power factor	%	NA	0.36%	0.25%	0.24%	0.18%	0.20%	0.21%	0.42%
200kVA Transformer No Load Losses	kW					0.6			
200 kVA Transformer Load Losses	kW					3.120			
Actual transformer Losses	kW	NA	0.28	0.28	0.28	0.28	0.28	0.28	0.28
	MU	NA	0.000198	0.000205	0.000198	0.000205	0.000198	0.000185	0.000198
	%	NA	0.17%	0.14%	0.13%	0.10%	0.09%	0.08%	0.07%
ES3 Street Light TR-315kVA Transformer Losses									
315kVA Transformer Street Light		NA	NA	NA	85	142	1767	3551.5	2285
Total Load	kWh	NA	NA	NA	85.0	142.0	1767.0	3551.5	2285.0
Operation Period	Days	NA	NA	NA	30	31	30	28	30
Average Electricity Consumption per Hour	kWh	NA	NA	NA	0.1	0.2	2.5	5.3	3.2
Transformer Loading @ 0.95 power factor	%	NA	NA	NA	0.00%	0.00%	0.03%	0.07%	0.04%
200kVA Transformer No Load Losses	kW					0.434			
200 kVA Transformer Load Losses	kW					3.100			
Actual transformer Losses	kW	NA	NA	NA	0.43	0.43	0.43	0.43	0.43
	MU	NA	NA	NA	0.000156	0.000161	0.000156	0.000146	0.000156
	%	NA	NA	NA	0.10%	0.08%	0.07%	0.06%	0.05%

Note: As the IT enable system is not available at JNPT SEZ substation, the losses have been evaluated with reference to electricity input at 220kV, consumer bills and electrical distribution network (RMU).

The details of overall T & D losses are as under,

Description	Unit	Aug-21	Sep-21	Oct-21	Nov-21	Dec-21	Jan-22	Feb-22	Mar-22
Main Transformer TR-1 & TR-2 (50 MVA X 2 nos.)	%	23.0%	27.8%	22.7%	12.9%	8.0%	7.5%	6.6%	5.5%
ES1-TR 1 & TR 2-(8 MVA X 2 nos.)	%	NA	8.5%	6.9%	6.2%	4.9%	4.5%	4.0%	3.4%
ES2-TR-1 & TR-2- (8MVA X 2nos.)	%	NA	8.5%	6.9%	6.2%	4.9%	4.5%	4.0%	3.4%
ES2-TR-3 & TR-4- (8 MVA X 2nos.)	%	NA	8.5%	6.9%	6.2%	4.9%	4.5%	4.0%	3.4%
ES2 TR-200kVA	%	NA	0.1%	0.1%	0.1%	0.0%	0.0%	0.0%	0.0%
Transformer 500 KVA	%	NA	0.2%	0.1%	0.1%	0.1%	0.1%	0.1%	0.1%
ES3 Street Light TR-315kVA Transformer Losses	%	NA	NA	NA	0.1%	0.1%	0.1%	0.1%	0.1%
All Transformer Losses	%	23.0%	53.5%	43.7%	31.7%	22.8%	21.3%	18.7%	15.8%
Distribution line & service connection Losses	%	NA	7.2%	6.2%	9.8%	7.7%	5.9%	7.3%	1.8%
Technical Losses @ commissioning phase	%	77.0%	NA	NA	NA	NA	NA	NA	NA
Total Losses	%	100.0%	60.7%	49.9%	41.5%	30.5%	27.2%	26.0%	17.6%

For transformer loading calculation the power factor is taken from the measurement only, data is not available for individual transformer.

- The month of August 2021 is commissioning phase for JNPT SEZ Substation.
- In the month of August 2021, the transformer losses are ~23%, and the remaining losses of ~77% are technical losses due to the commissioning of the substation with **zero** active consumer.
- From the month of August 2021, the overall losses have gradually reduced. The distribution line and service connection losses are around~1.8% in the month of March 2022.

The details of annual consumption and losses are as under,

Description	Units	Value	%
Annual Electricity Consumption	MU	1.438226	100.00%
Electricity Consumption at Consumer End	MU	0.907162	63.08%
Overall T & D Losses	MU	0.531064	36.92%
Overall T & D Losses			
Main Transformer Losses TR-1 & TR-2 (50 MVA X 2 nos.)	MU	0.169356	11.78%
Transformer Losses ES1-TR 1 & TR 2-(8 MVA X 2 nos.)	MU	0.067562	4.70%
Transformer Losses ES2-TR-1 & TR-2- (8MVA X 2nos.)	MU	0.067545	4.70%
Transformer Losses ES2-TR-3 & TR-4- (8 MVA X 2nos.)	MU	0.067544	4.70%
ES1 TR-200kVA Transformer Losses	MU	0.001386	0.10%
ES2 TR-200kVA Transformer Losses	MU	0.000693	0.05%
Station TR-500kVA Transformer Losses	MU	0.001386	0.10%
ES3 Street Light TR-315kVA Transformer Losses	MU	0.000776	0.05%
Technical Losses at Commissioning Phase	MU	0.074001	5.15%
Distribution line & service connection Losses	MU	0.080816	5.62%

- Reference to BEE -ENERGY_EFFICIENCY_IN_ELECTRICAL_UTILITIES_BOOK_03/ (Electrical System, Page no 24, Table no 1.6), the distribution line & service connection losses are within the maximum limit of ~7.0%.

Note: Consumer (Industries) electrical consumption starts from September 2021, while in the month of August 2021, transformer losses are considered only for 50 MVA transformer and the remaining are the technical losses for the commissioning substation.

5.1.3.3 Consumer Electrical Consumption

- The details of electrical consumption for year 2021-2022, are as under,

Description	Unit	Sep-21	Oct-21	Nov-21	Dec-21
Total Electricity Consumption at consumer End	MU	0.044675	0.072177	0.091115	0.142174
M/s Simosis International	kWh	1004.0	2299.0	2023.0	2273.0
M/s Krish Food Industry (India)	kWh	1124.0	10891.0	27050.0	70323.0
M/s Sarveshwar Logistics Services Pvt Ltd	kWh	NA	1053	715	663
M/s Rudra Flexipack LLP	kWh	NA	NA	NA	NA
M/s R K Sweets Mars Pvt Ltd	kWh	NA	NA	NA	832
M/s Sadanand Engineering Works	kWh	NA	NA	NA	NA
315KVA Transformer Street Light	kWh	NA	NA	85	142.0
M/s Piyush Enterprises	kWh	NA	344.0	844.0	642.0
M/s Nhava Sheva Business Parks Pvt Ltd	kWh	16450.0	30005.0	33025.0	40345.0
Admin Building	kWh	2043.0	8476.2	9254.7	12298.0
E1 & E2 SS-200kVA Transformer Street Light	kWh	8.0	1200.0	1334.0	1088.0
E1 & E2 SS-200kVA Station Transformer-01	kWh	3490.0	3577.0	3169.0	3204.0
Station Transformer- 500kVA	kWh	20556.5	14332.0	13615.0	10364.4

Description	Unit	Jan-22	Feb-22	Mar-22
Total Electricity Consumption at consumer End	MU	0.154630	0.166685	0.235704
M/s Simosis International	kWh	2679.0	2368.4	2846.4
M/s Krish Food Industry (India)	kWh	69782.0	69115.0	82605.5
M/s Sarveshwar Logistics Services Pvt Ltd	kWh	645.0	372.6	779.4
M/s Rudra Flexipack LLP	kWh	1175.0	4668.4	2437.2
M/s R K Sweets Mars Pvt Ltd	kWh	2872.0	12072.4	42056.4
M/s Sadanand Engineering Works	kWh	52.2	45.8	132.1
315KVA Transformer Street Light	kWh	1767.0	3551.5	2285.0
M/s Piyush Enterprises	kWh	602.0	398.0	836.0
M/s Nhava Sheva Business Parks Pvt Ltd	kWh	47435.0	48637.5	56705.0
Admin Building	kWh	9063.0	7331.0	11624.0
ES1 & ES2 SS-200kVA Transformer Street Light	kWh	2284.0	2724.0	4655.0
ES1 & ES2 SS-200kVA Station Transformer-01	kWh	4997.0	4495.9	5009.1
Station Transformer- 500kVA	kWh	11277.3	10904.2	23733.4

- The total active consumers by the end of March 2022 are 13 nos. including utility consumers.

5.2 Performance Assessment & Observations

• Introduction:

The audit of plant operations, data collection, observations, field trials and analysis of various areas was undertaken, keeping in view the energy scene at the unit, focus areas elaborated in the previous chapter and with a view to identify energy conservation opportunities in the same. The basis for this is the orientation visit, discussions with the plant personnel and the agreed plan for data collection and field trials. All these trials were undertaken at normal operating conditions.

5.2.1 Power Supply and Distribution

5.2.2 Transformer

- The performance and loading pattern were studies for all the operational transformers.

Description		Unit	TR-1 50 MVA	Main Station	E2-SS TR-1	E1-SS TR-1
Make			Voltamp	Voltamp	Talawane	Talawane
TR Capacity		kVA	50000	500	8000	8000
Voltage	Primary	kV	220.0	33.0	33.0	33.0
	Secondary	kV	33.000	11.000	11.000	11.000
Data As per Test Certificate	No Load Loss	kW	21.98	0.60	6.70	6.70
	Full Load Loss	kW	146.63	3.12	58.00	58.00
CT Ratio	Primary	A	800	100	300	300
	Secondary	A	1	1	1	1
PT Ratio	Primary	kV	33	33	33	33
	Secondary	V	110	110	110	110
Voltage		kV	32.880	32.917	32.980	32.953
Current		A	12.9	0.6	1.7	8.9
Power Factor			0.950	0.978	0.268	0.981
Total Power		kW	696.0	34.8	25.7	496.7
		kVA	732.3	35.6	95.9	506.5
Average loading		%	1.5%	7.1%	1.2%	6.3%
Actual Losses		kW	22.01	0.62	6.71	6.93
Efficiency		%	96.8%	98.2%	73.9%	98.6%

Description		Unit	E2-SS-TR-4	E1-SS-Station TR	E2-Street Light TR
Rated Parameter					
Make			Talawane	Super Power Equipments Pvt Ltd	Super Power Equipments Pvt Ltd
TR Capacity		kVA	8000	200	200
Voltage	Primary	kV	33.0	11.0	11.0
	Secondary	kV	11.000	433.000	433.000
Data As per Test Certificate	No Load Loss	kW	6.70	0.28	0.28
	Full Load Loss	kW	58.00	2.28	2.28
Actual Parameter					
CT Ratio	Primary	A	300	630	10
	Secondary	A	1	1	1
PT Ratio	Primary	kV	33	11	11
	Secondary	V	110	110	110
Voltage		kV	33.460	11.1	11.2
Current		A	2.2	1.1	0.7
Power Factor			0.987	0.933	0.985
Total Power		kW	126.0	20.2	12.6
		kVA	127.6	21.6	12.8
Average loading		%	1.6%	10.8%	6.4%
Actual Losses		kW	6.71	0.31	0.29
Efficiency		%	94.7%	98.5%	97.7%

Observations:

- The average load on sub-station 50 MVA transformer is around 1.5%.
- Most of the transformer efficiency is lower due to the lower loading of the transformer.

5.2.3 Power Quality Analysis

- The power consumption and quality analysis were carried out by log-In the data; the details are as under. In the table the details are given with average, minimum and maximum values of respective parameters.

5.2.3.1 Main Incomer Transformer 50MVA Main Incomer

- Voltage Ph-N

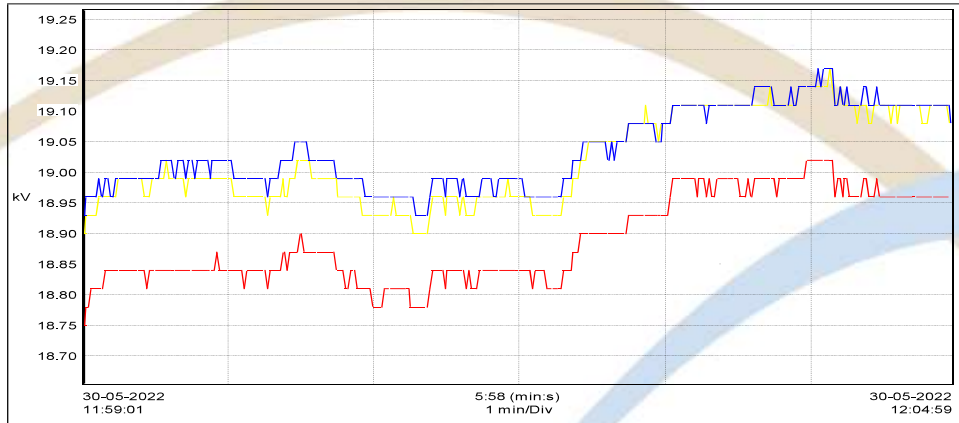

Description	Unit	Average	Min	Max
V1 rms	kV	18.89	18.66	19.11
V2 rms	kV	19.02	18.81	19.2
V3 rms	kV	19.04	18.78	19.26

- Voltage Ph-Ph

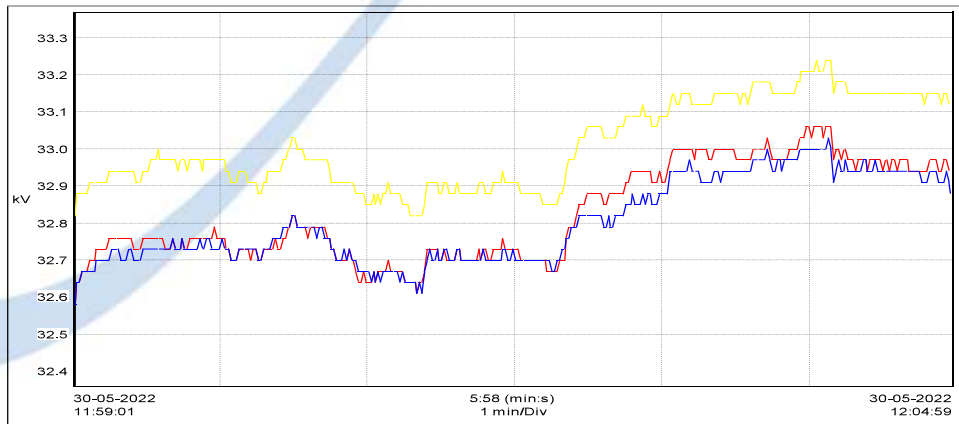

Description	Unit	Average	Min	Max
U12 rms	kV	32.83	32.46	33.18
U23 rms	kV	33.01	32.64	33.36
U31 rms	kV	32.8	32.37	33.18

- **Current**

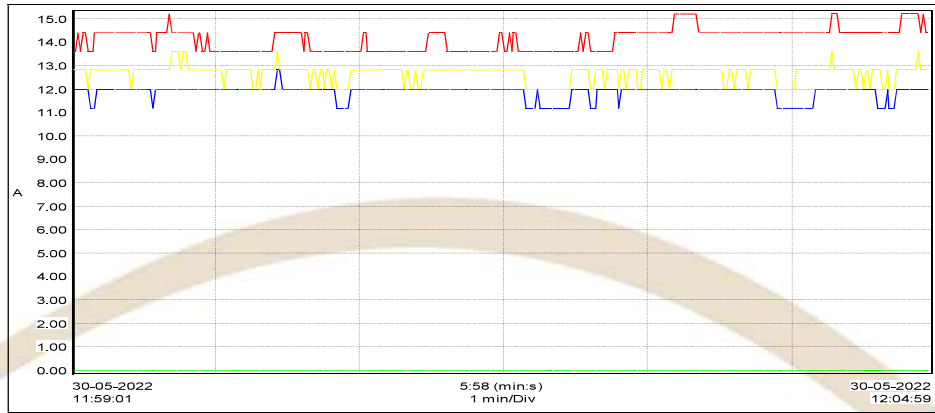

Description	Unit	Average	Min	Max
A1 rms	A	14.13	12	15.2
A2 rms	A	12.67	11.2	13.6
A3 rms	A	11.89	10.4	12.8

- **Active Power**

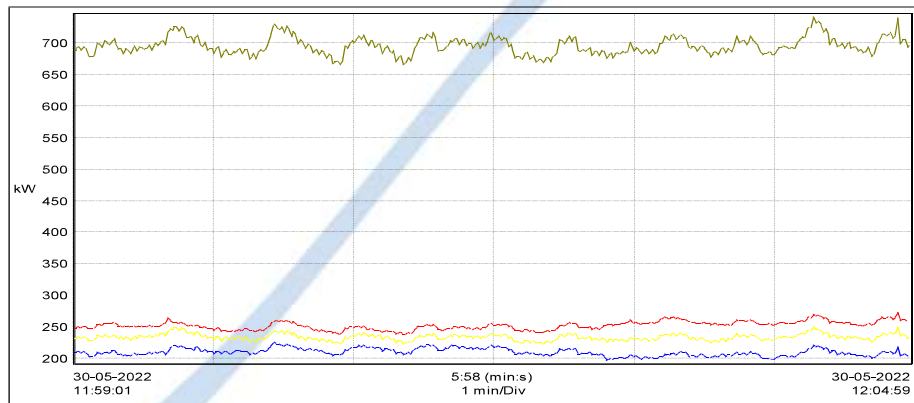

Description	Unit	Average	Min	Max
P1 (W)	kW	252.4	238.2	273.1
P2 (W)	kW	233.7	222.1	250.4
P3 (W)	kW	210	196.7	226
PT (W)	kW	696	665.8	742.2

- **Reactive Power (kVar)**

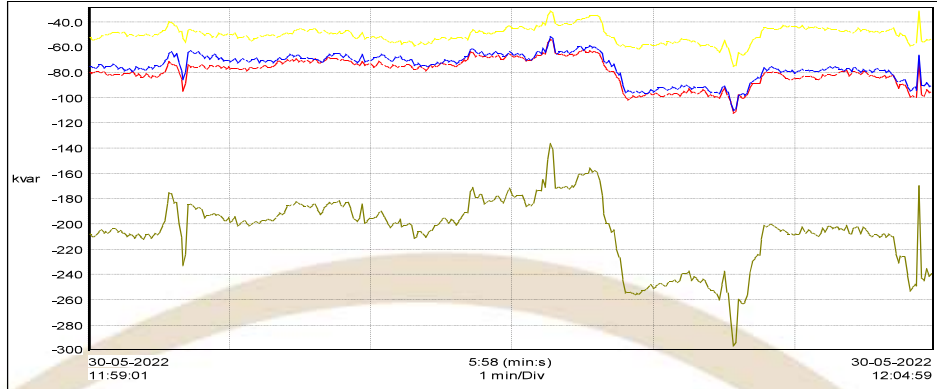

Description	Unit	Average	Min	Max
Q1 (var)	kvar	-79.46	-111.8	-53.48
Q2 (var)	kvar	-50.02	-75.04	-30.97
Q3 (var)	kvar	-75.31	-109.7	-51.36
QT (var)	kvar	-204.8	-296.5	-135.8

• **Power factor**

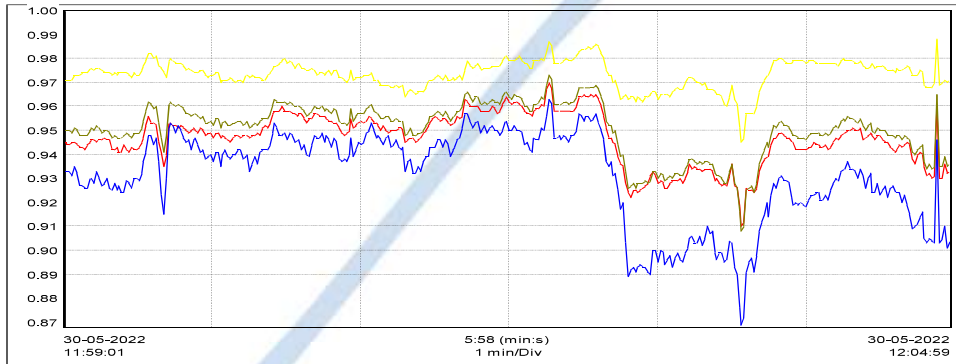

Description	Average	Min	Max
PF1	0.947	0.91	0.97
PF2	0.973	0.945	0.988
PF3	0.931	0.869	0.963
PFT	0.951	0.908	0.973

Observations and Remarks:

- The average recorded power factor is 0.951, leading with average reactive power - 204.8kVAr.
- The voltage imbalance is ~0.4%, which is within the stipulated limits.
- The average transformer loading is ~1.5%.

5.2.3.2 Station transformer-500KVA

- Voltage Ph-N

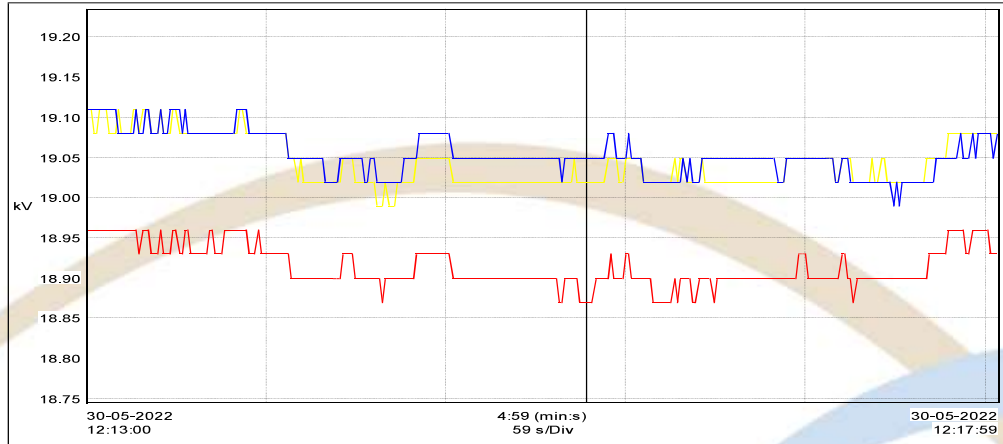

Description	Unit	Average	Min	Max
V1 rms	kV	18.91	18.75	19.05
V2 rms	kV	19.04	18.9	19.2
V3 rms	kV	19.05	18.87	19.23

- Voltage Ph-Ph

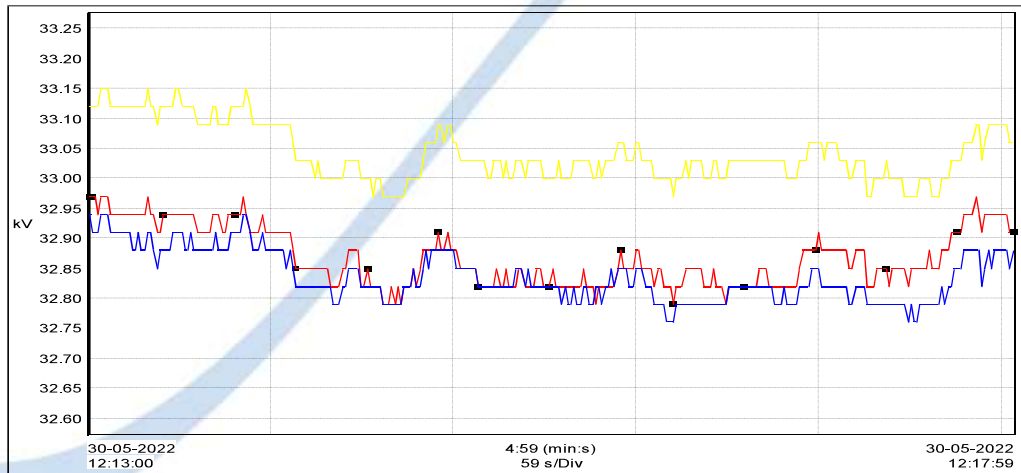

Description	Unit	Average	Min	Max
U12 rms	kV	32.87	32.64	33.09
U23 rms	kV	33.04	32.82	33.27
U31 rms	kV	32.84	32.58	33.09

• **Current**

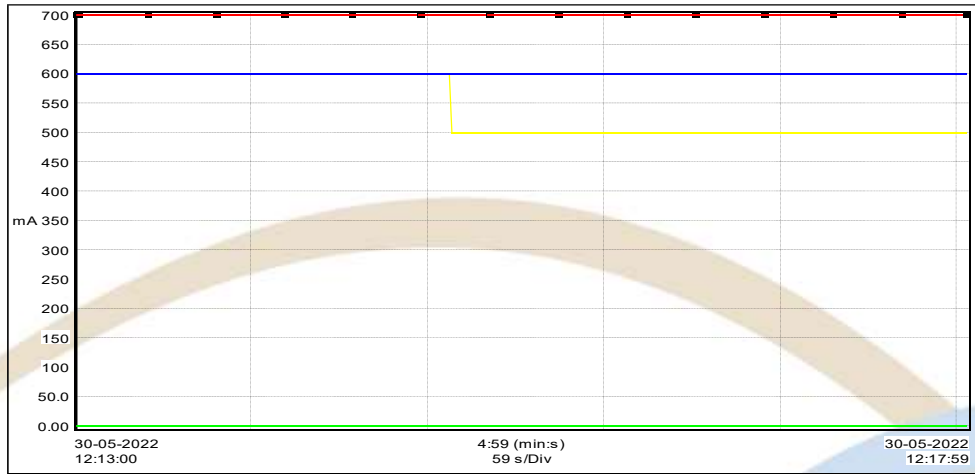

Description	Unit	Average	Min	Max
A1 rms	A	0.7	0.6	0.7
A2 rms	A	0.544	0.3	0.6
A3 rms	A	0.6	0.3	0.6

• **Active Power**

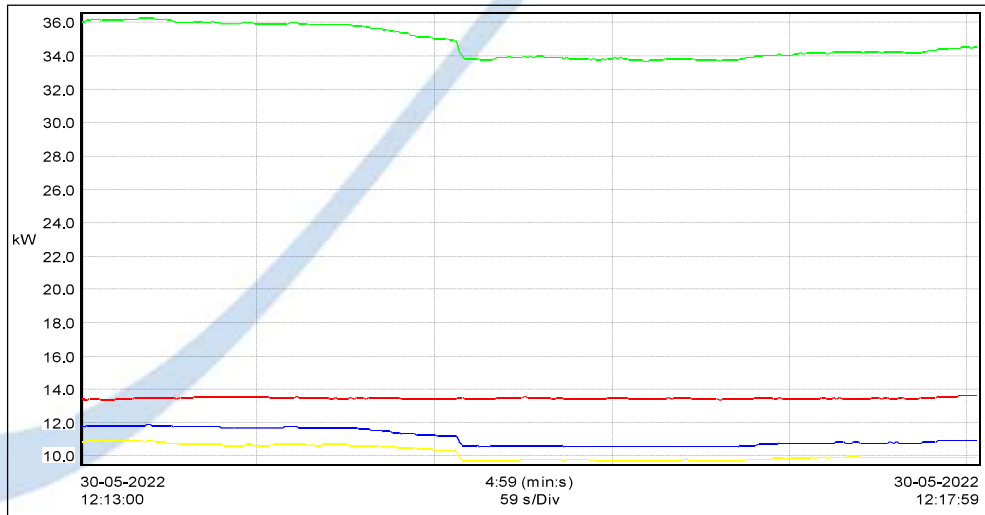

Description	Unit	Average	Min	Max
P1 (W)	kW	13.5	13.39	13.67
P2 (W)	kW	10.2	9.732	10.95
P3 (W)	kW	11.11	10.56	11.88
PT (W)	kW	34.81	33.73	36.33

• Apparent power (kVA)

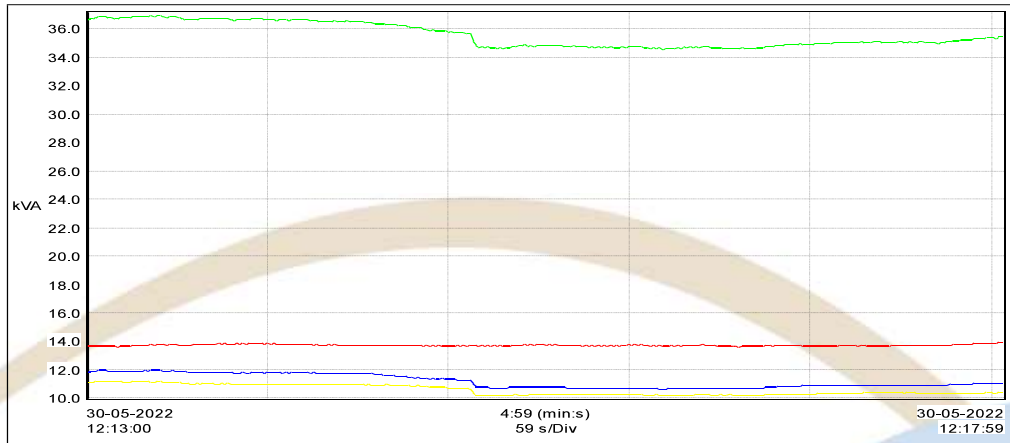

Description	Unit	Average	Min	Max
S1 (VA)	kVA	13.75	13.64	13.93
S2 (VA)	kVA	10.61	10.22	11.23
S3 (VA)	kVA	11.22	10.69	11.97
ST (VA)	kVA	35.58	34.58	36.96

• Reactive Power (kVar)

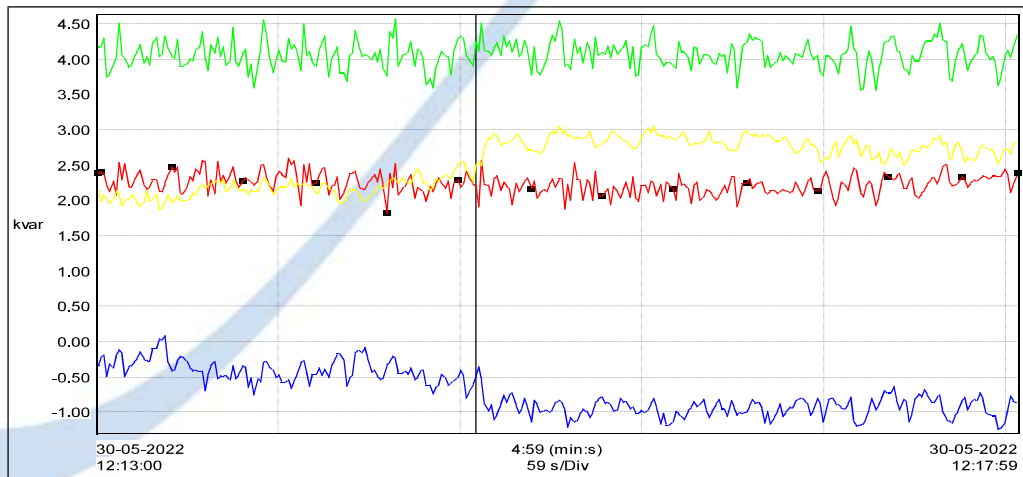

Description	Unit	Average	Min	Max
Q1 (var)	kvar	2.238	1.824	2.596
Q2 (var)	kvar	2.538	1.87	3.064
Q3 (var)	kvar	-0.707	-1.241	0.088
QT (var)	kvar	4.07	3.567	4.578

• **Power factor**

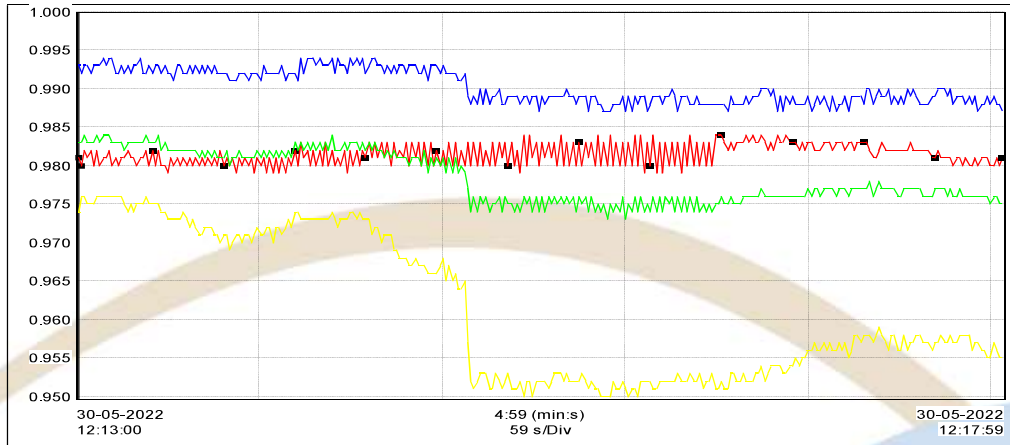

Description	Average	Min	Max
PF1	0.981	0.979	0.984
PF2	0.961	0.95	0.976
PF3	0.99	0.987	0.994
PFT	0.978	0.973	0.984

Observations and Remarks:

- The average recorded power factor is 0.978, lagging with average reactive power - 4.07kVAr.
- The voltage imbalance is ~0.4%, which is within the stipulated limits.
- The average transformer loading is ~7.1%.

5.2.3.3 E1SSI/C-1

- Voltage Ph-N

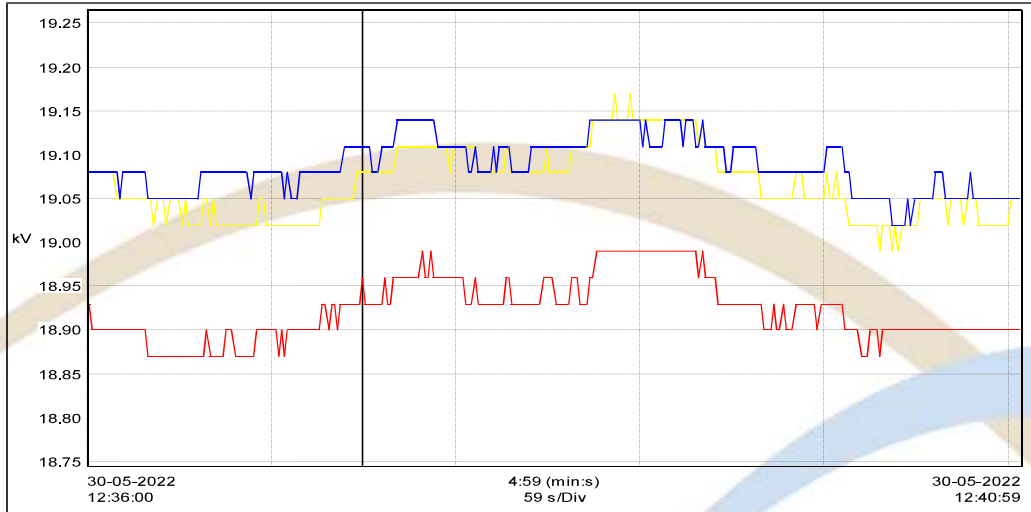

Description	Unit	Average	Min	Max
V1 rms	kV	18.92	18.75	19.11
V2 rms	kV	19.07	18.9	19.23
V3 rms	kV	19.09	18.9	19.26

- Voltage Ph-Ph

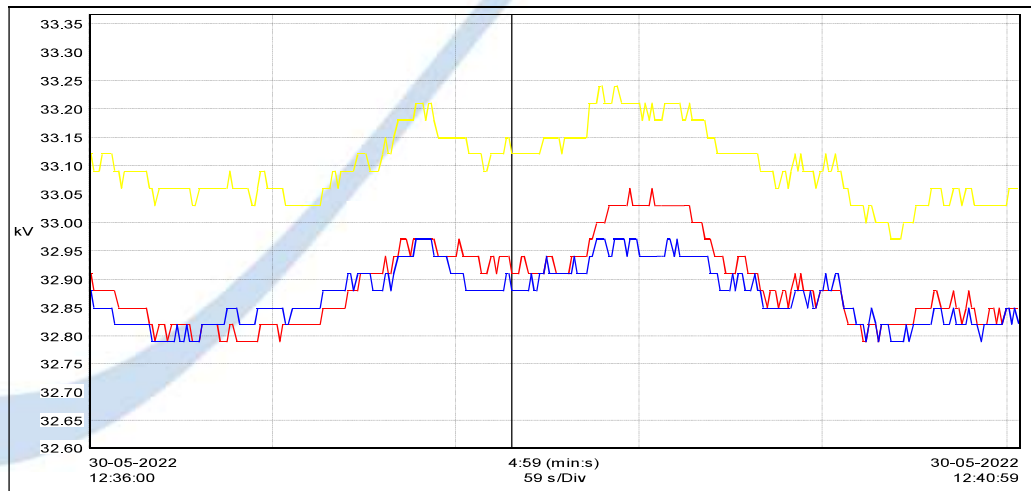

Description	Unit	Average	Min	Max
U12 rms	kV	32.89	32.64	33.21
U23 rms	kV	33.1	32.82	33.36
U31 rms	kV	32.87	32.61	33.15

• **Current**

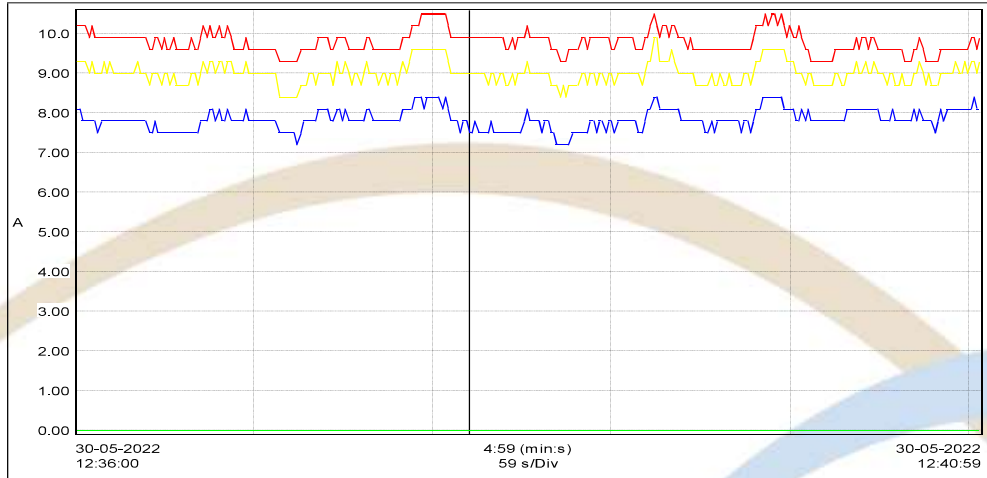

Description	Unit	Average	Min	Max
A1 rms	A	9.787	9	10.5
A2 rms	A	9.007	7.8	9.9
A3 rms	A	7.836	6.6	8.7

• **Active Power**

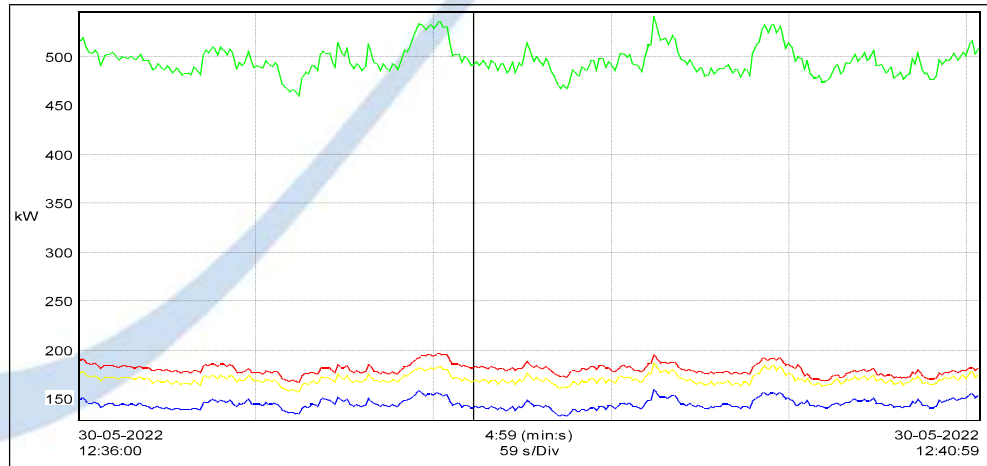

Description	Unit	Average	Min	Max
P1 (W)	kW	180.7	168	196.8
P2 (W)	kW	170.6	157.7	186.8
P3 (W)	kW	145.4	132.8	159.8
PT (W)	kW	496.7	460.4	542.1

- **Apparent power (kVA)**

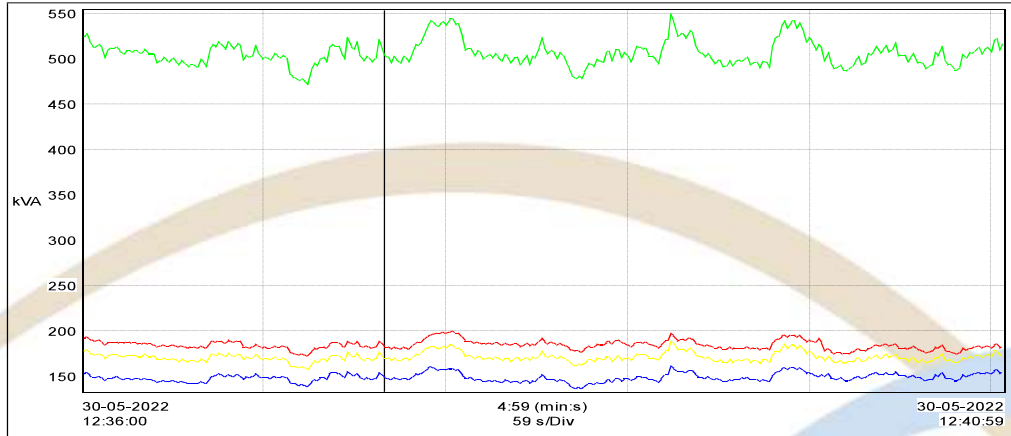

Description	Unit	Average	Min	Max
S1 (VA)	kVA	185.3	173.6	200.1
S2 (VA)	kVA	171.8	158.6	189.5
S3 (VA)	kVA	149.4	137.2	162.5
ST (VA)	kVA	506.5	472	550.2

- **Reactive Power (kVAr)**

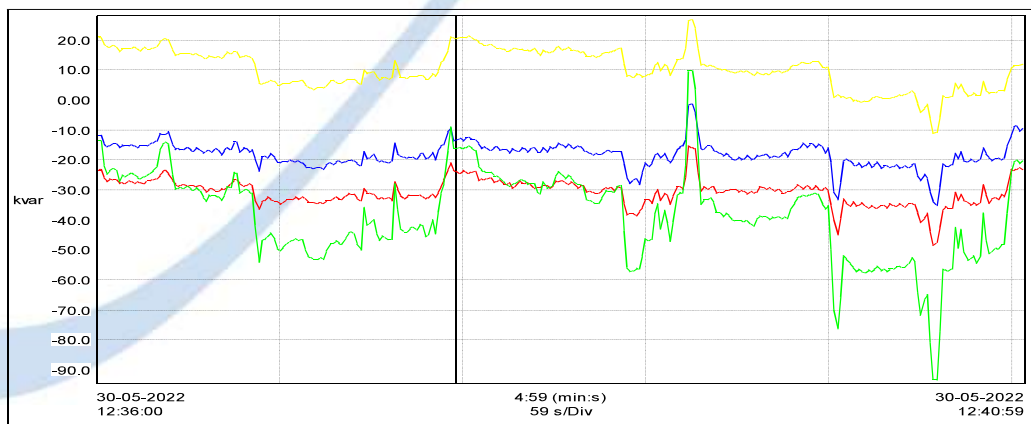

Description	Unit	Average	Min	Max
Q1 (var)	kvar	-30.56	-48.34	-15.18
Q2 (var)	kvar	10.47	-11.03	26.94
Q3 (var)	kvar	-18.06	-35.07	-1.27
QT (var)	kvar	-38.15	-93.19	9.97

• **Power factor**

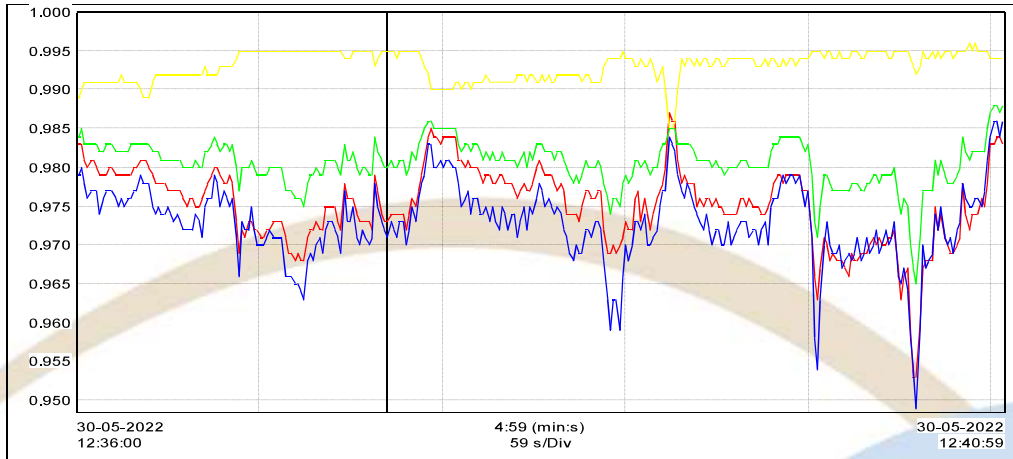

Description	Average	Min	Max
PF1	0.975	0.953	0.987
PF2	0.993	0.985	0.996
PF3	0.973	0.949	0.986
PFT	0.981	0.965	0.988

Observations and Remarks:

- The average recorded power factor is 0.981, leading with average reactive power - 38.15kVAr.
- The voltage imbalance is ~0.4%, which is within the stipulated limits.
- The average transformer loading is ~6.1%.

5.2.3.4 E2 SS-I/C-1

- Voltage Ph-N

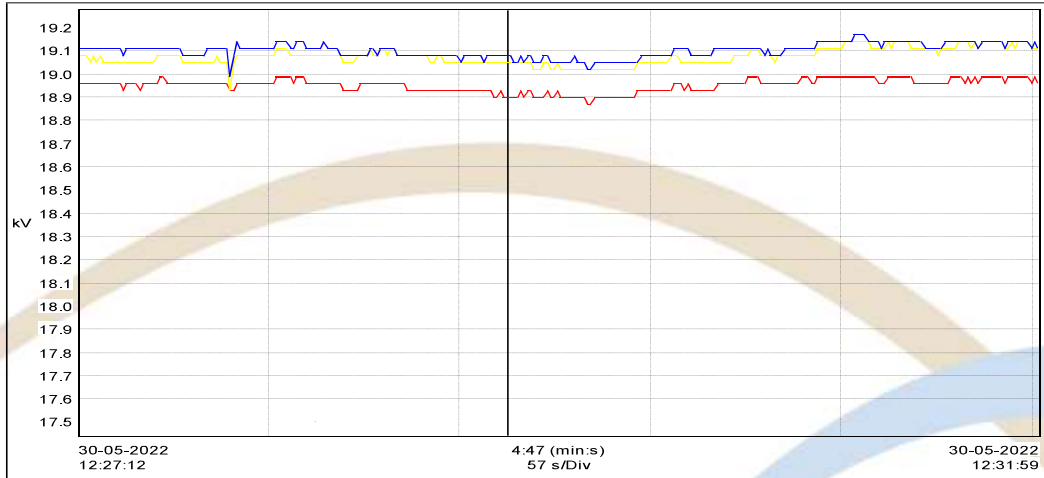

Description	Unit	Average	Min	Max
V1 rms	kV	18.95	18.51	19.08
V2 rms	kV	19.08	17.46	19.23
V3 rms	kV	19.1	17.49	19.26

- Voltage Ph-Ph

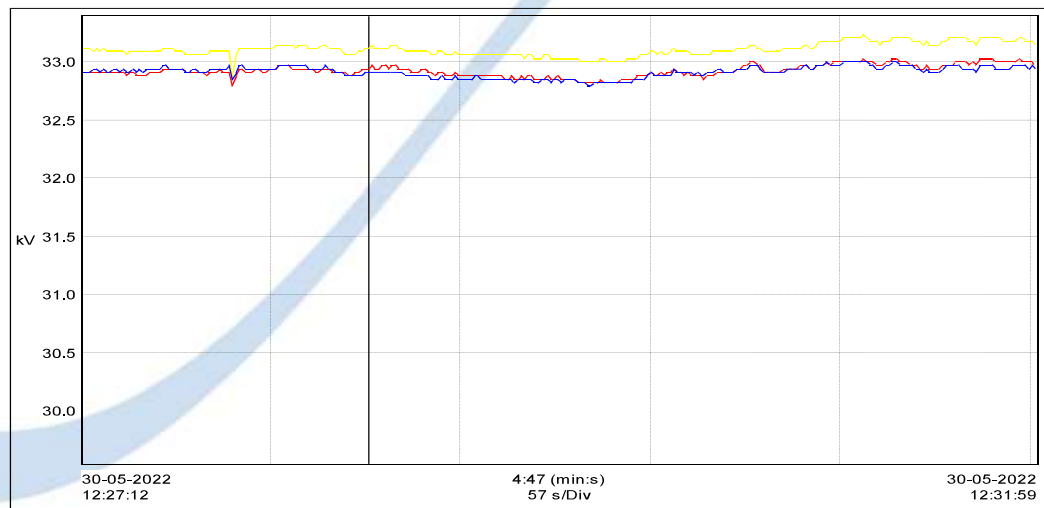

Description	Unit	Average	Min	Max
U12 rms	kV	32.92	31.59	33.15
U23 rms	kV	33.11	29.58	33.36
U31 rms	kV	32.91	31.59	33.18

• **Current**

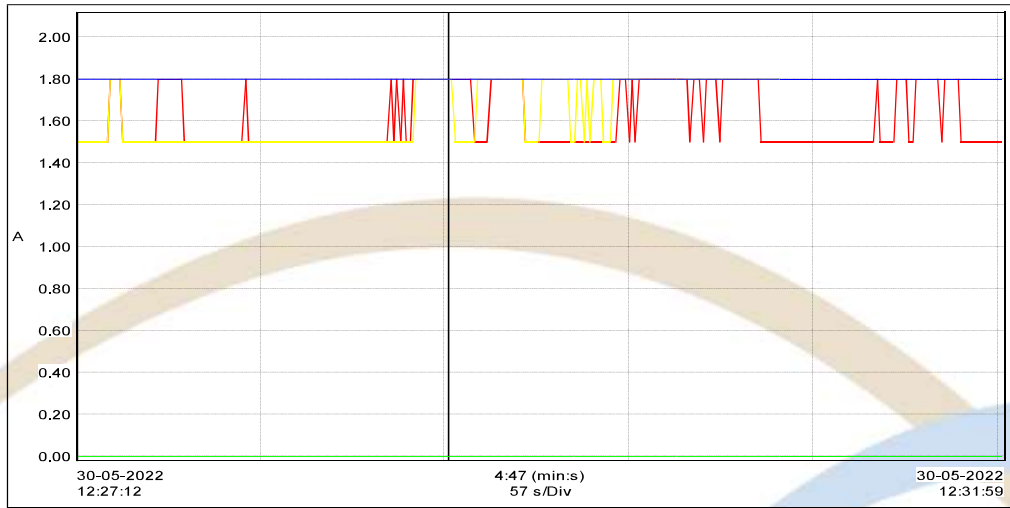

Description	Unit	Average	Min	Max
A1 rms	A	1.614	0.9	1.8
A2 rms	A	1.682	0.9	1.8
A3 rms	A	1.8	0.9	2.1

• **Active Power**

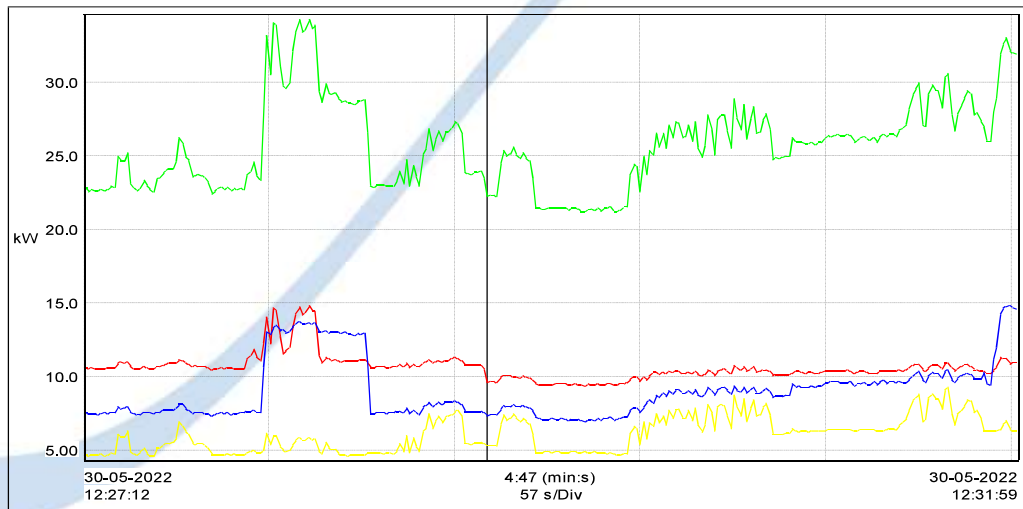

Description	Unit	Average	Min	Max
P1 (W)	kW	10.62	9.387	14.78
P2 (W)	kW	6.053	4.574	9.272
P3 (W)	kW	9.037	6.953	14.8
PT (W)	kW	25.71	21.21	34.29

• Apparent power (kVA)

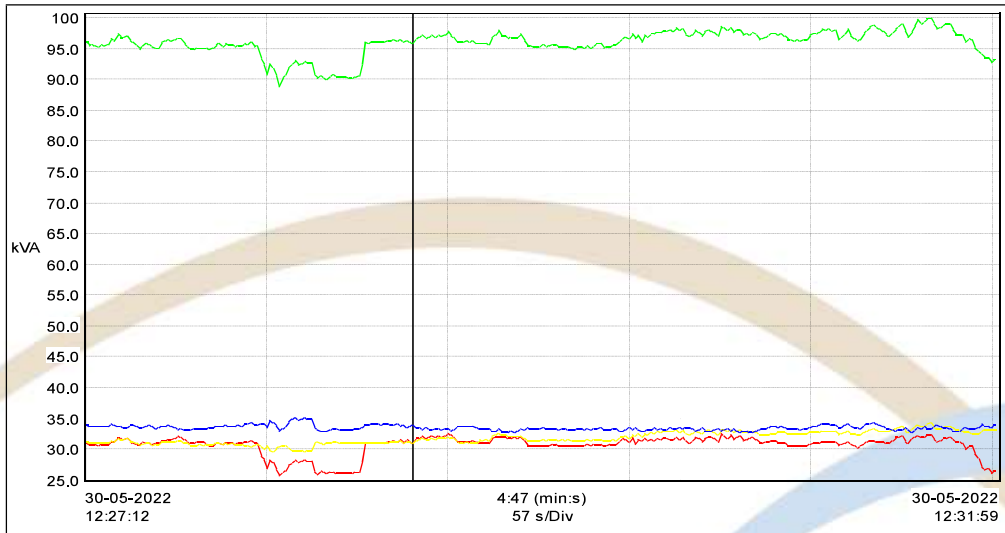

Description	Unit	Average	Min	Max
S1 (VA)	kVA	30.67	25.68	32.5
S2 (VA)	kVA	31.87	29.64	34.32
S3 (VA)	kVA	33.52	32.69	35.17
ST (VA)	kVA	96.06	88.92	100.1

• Reactive Power (kVar)

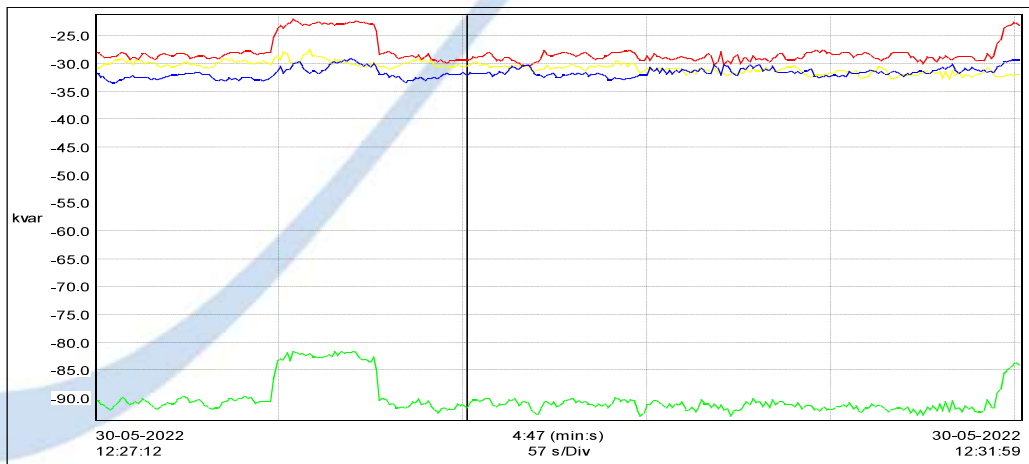

Description	Unit	Average	Min	Max
Q1 (var)	kvar	-27.87	-30.36	-21.87
Q2 (var)	kvar	-30.6	-32.8	-27.34
Q3 (var)	kvar	-31.56	-33.28	-29.09
QT (var)	kvar	-90.03	-93.23	-81.5

• **Power factor**

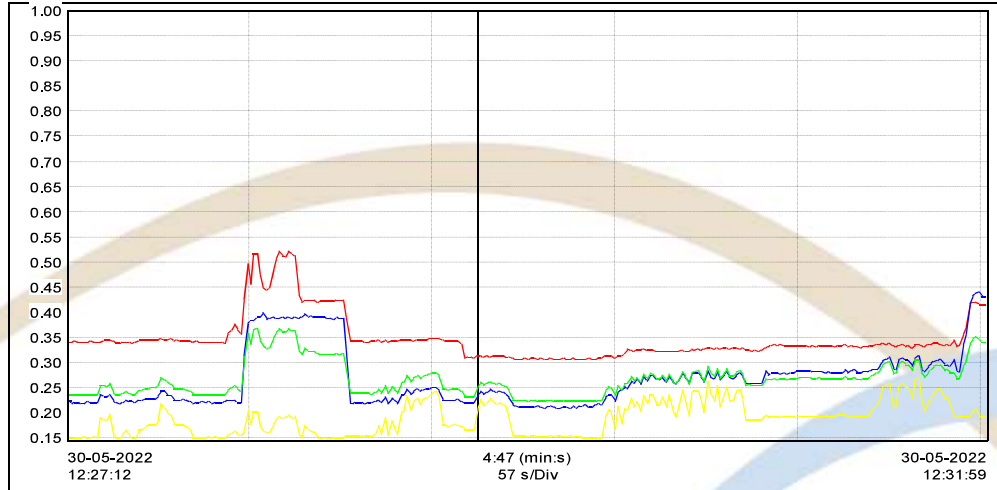

Description	Average	Min	Max
PF1	0.348	0.307	0.523
PF2	0.189	0.148	0.27
PF3	0.269	0.21	0.441
PFT	0.268	0.223	0.369

Observations and Remarks:

- The average recorded power factor is 0.268, leading with average reactive power - 90.03kVAR.
- The voltage imbalance is ~0.4%, which is within the stipulated limits.
- The average transformer loading is ~1.2%.
- It is recommended to maintain near unity power factor to optimize the losses of ~70kW.

5.2.3.5 E2SSI/C-2

- Voltage Ph-N

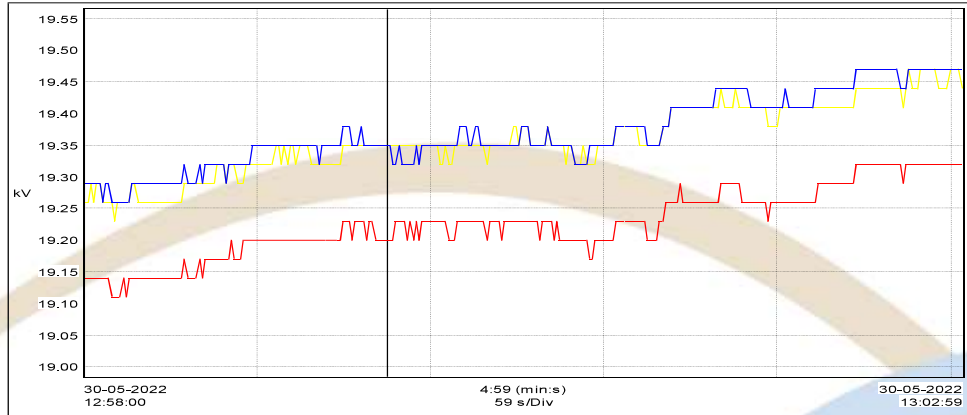

Description	Unit	Average	Min	Max
V1 rms	kV	19.23	18.99	19.44
V2 rms	kV	19.36	19.14	19.53
V3 rms	kV	19.37	19.14	19.56

- Voltage Ph-Ph

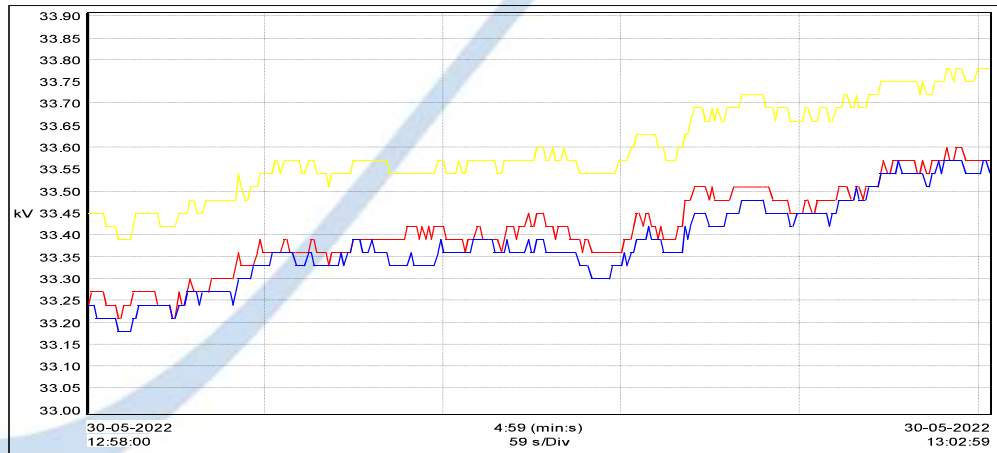

Description	Unit	Average	Min	Max
U12 rms	kV	33.41	33.06	33.69
U23 rms	kV	33.59	33.24	33.9
U31 rms	kV	33.38	33	33.72

• **Current**



Description	Unit	Average	Min	Max
A1 rms	A	2.233	1.5	4.8
A2 rms	A	2.13	1.5	4.5
A3 rms	A	2.232	1.5	4.5
AN rms	A	0	0	0

• **Active Power**



Description	Unit	Average	Min	Max
P1 (W)	kW	42.53	34.68	54.54
P2 (W)	kW	40.76	32.84	53.59
P3 (W)	kW	42.72	35.34	55.15
PT (W)	kW	126	102.9	163.3

• **Apparent power (kVA)**

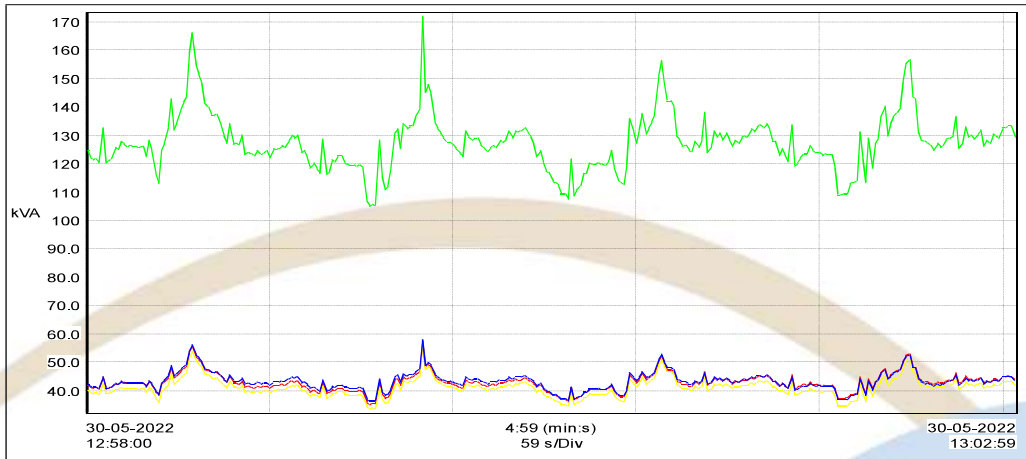

Description	Unit	Average	Min	Max
S1 (VA)	kVA	42.96	35.28	57.5
S2 (VA)	kVA	41.23	33.58	56.75
S3 (VA)	kVA	43.36	36.43	58.02
ST (VA)	kVA	127.6	105.3	172.3

• **Reactive Power (kVar)**

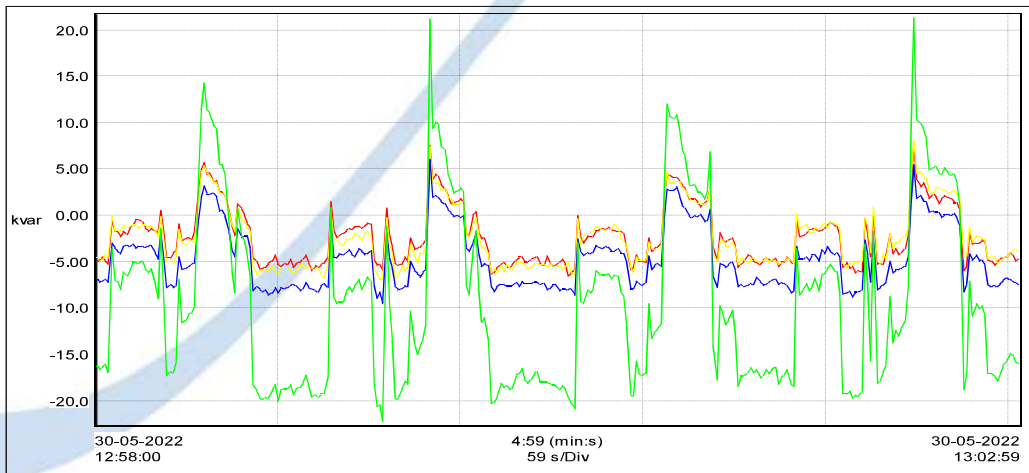

Description	Unit	Average	Min	Max
Q1 (var)	kvar	-2.285	-6.52	7.727
Q2 (var)	kvar	-2.411	-6.894	8.124
Q3 (var)	kvar	-4.655	-9.466	6.077
QT (var)	kvar	-9.351	-22.26	21.36

• **Power factor**

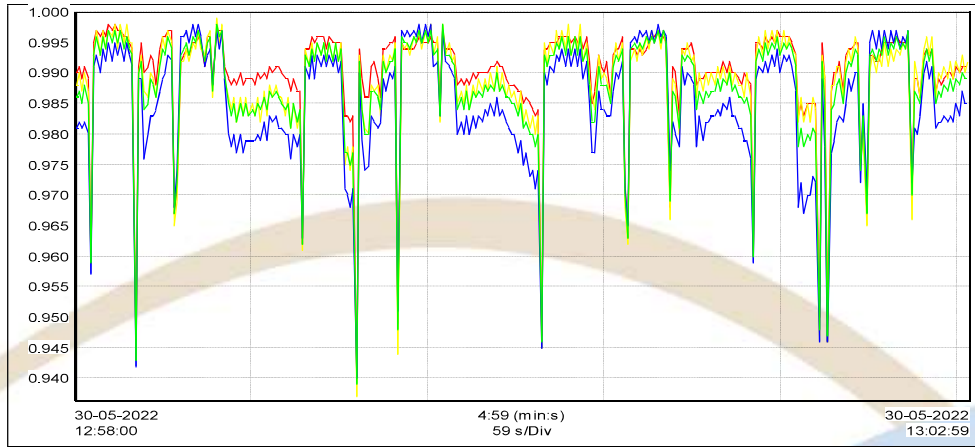

Description	Average	Min	Max
PF1	0.99	0.94	0.998
PF2	0.989	0.937	0.999
PF3	0.985	0.94	0.998
PFT	0.988	0.939	0.998

Observations and Remarks:

- The average recorded power factor is 0.988, leading with average reactive power - 9.351kVAR.
- The voltage imbalance is ~0.4%, which is within the stipulated limits.
- The average transformer loading is ~1.6%.

5.2.3.6 E1-SS Station TR-1

- Voltage Ph-N**

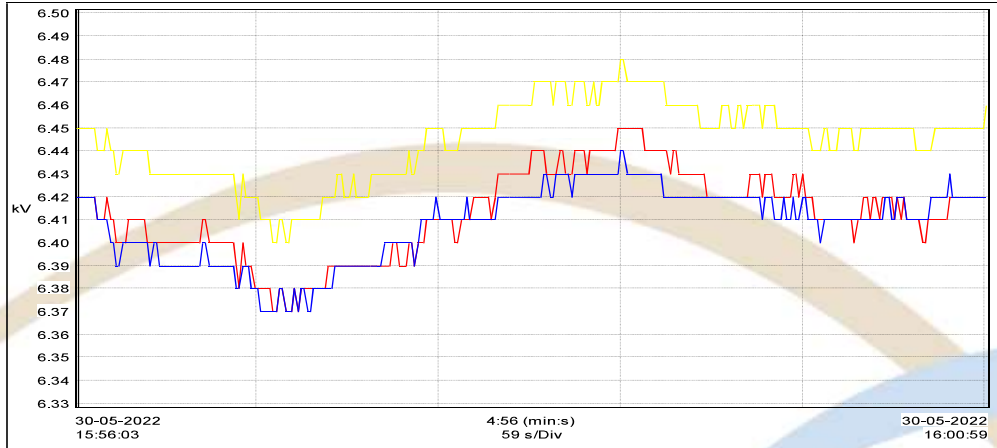

Description	Unit	Average	Min	Max
V1 rms	kV	6.413	6.34	6.48
V2 rms	kV	6.445	6.37	6.5
V3 rms	kV	6.408	6.33	6.46

- Voltage Ph-Ph**

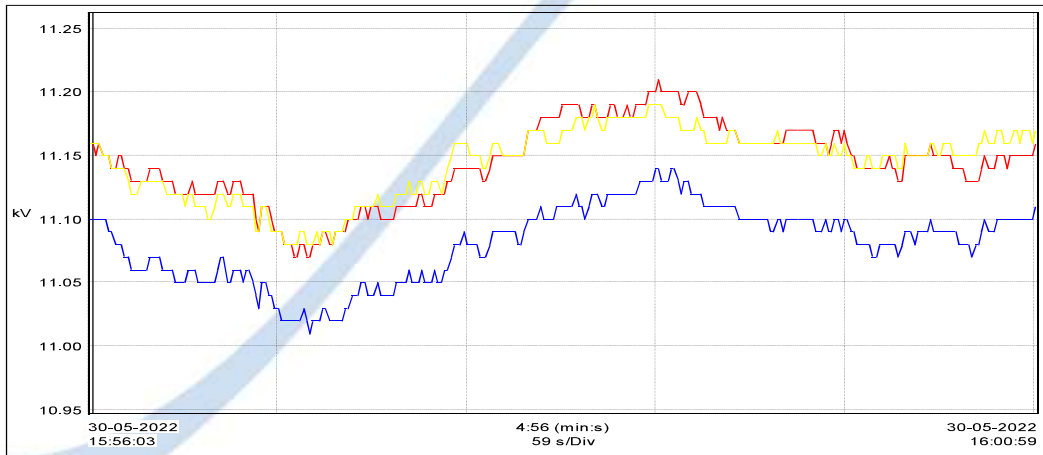

Description	Unit	Average	Min	Max
U12 rms	kV	11.14	11.02	11.26
U23 rms	kV	11.14	11.03	11.23
U31 rms	kV	11.08	10.95	11.19

- Current**

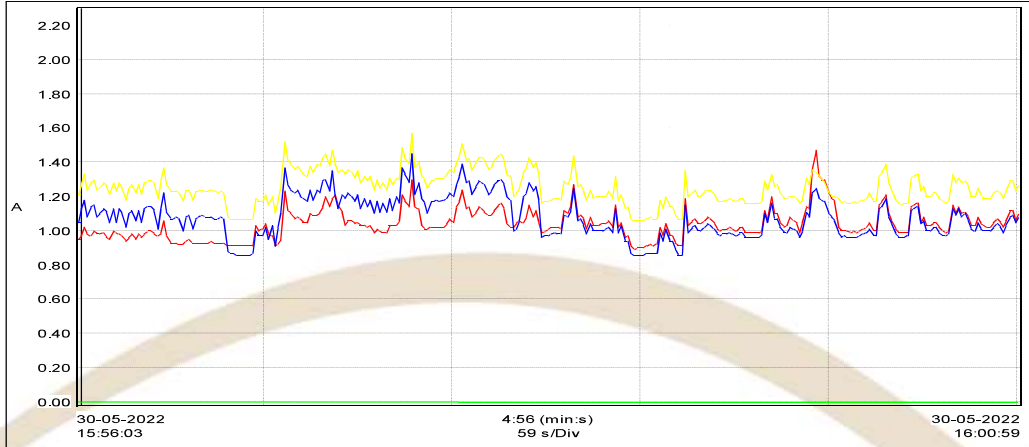

Description	Unit	Average	Min	Max
A1 rms	A	1.043	0.83	1.95
A2 rms	A	1.254	0.99	2.28
A3 rms	A	1.083	0.82	2.18
AN rms	A	0	0	0

• Active Power

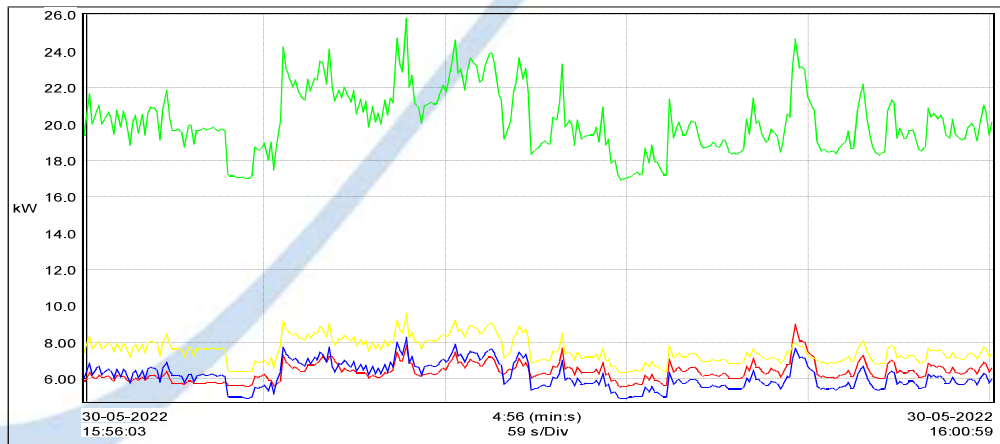

Description	Unit	Average	Min	Max
P1 (W)	kW	6.412	5.598	9.043
P2 (W)	kW	7.579	6.375	9.629
P3 (W)	kW	6.188	4.959	8.34
PT (W)	kW	20.18	16.93	25.87

• **Apparent power (kVA)**

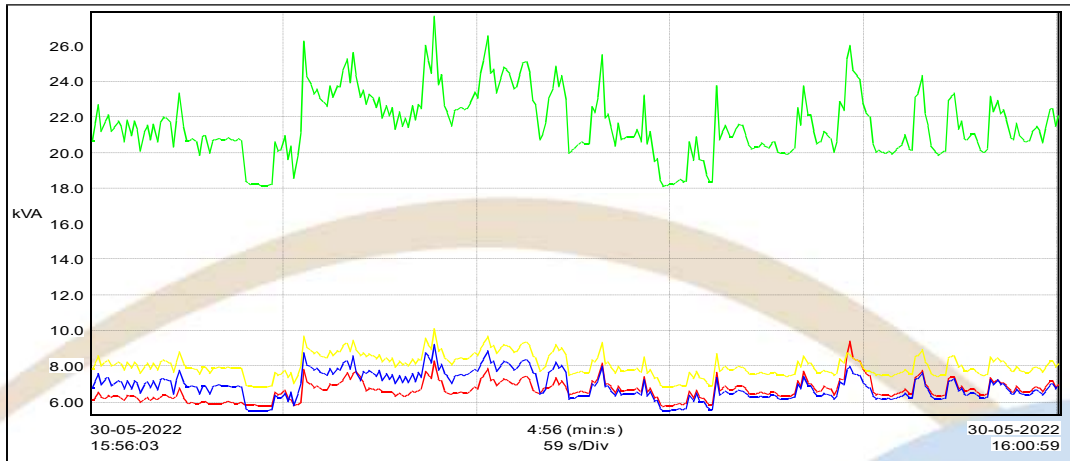

Description	Unit	Average	Min	Max
S1 (VA)	kVA	6.667	5.767	9.417
S2 (VA)	kVA	8.057	6.83	10.11
S3 (VA)	kVA	6.9	5.497	9.268
ST (VA)	kVA	21.62	18.1	27.7

• **Reactive Power (kVar)**

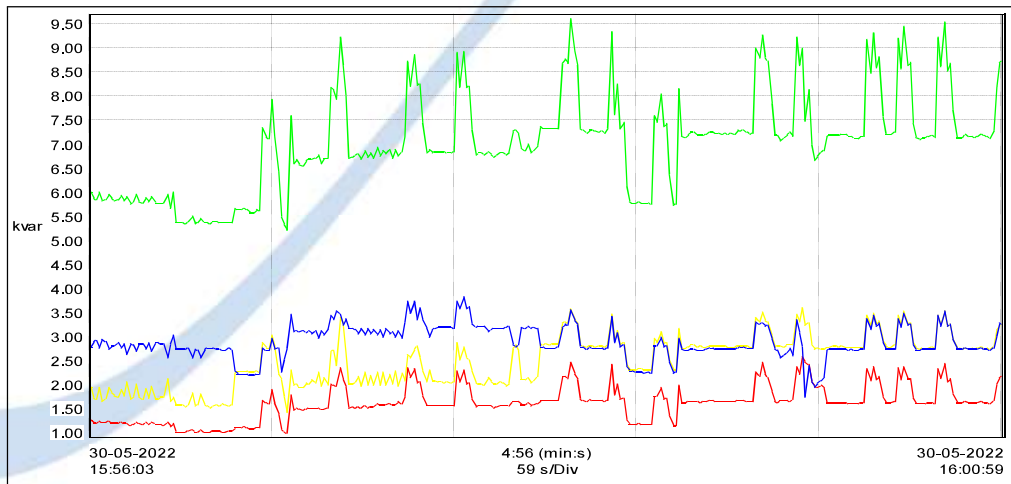

Description	Unit	Average	Min	Max
Q1 (var)	kvar	1.629	1.003	2.605
Q2 (var)	kvar	2.512	1.443	3.605
Q3 (var)	kvar	2.902	1.763	3.841
QT (var)	kvar	7.044	5.214	9.623

• **Power factor**

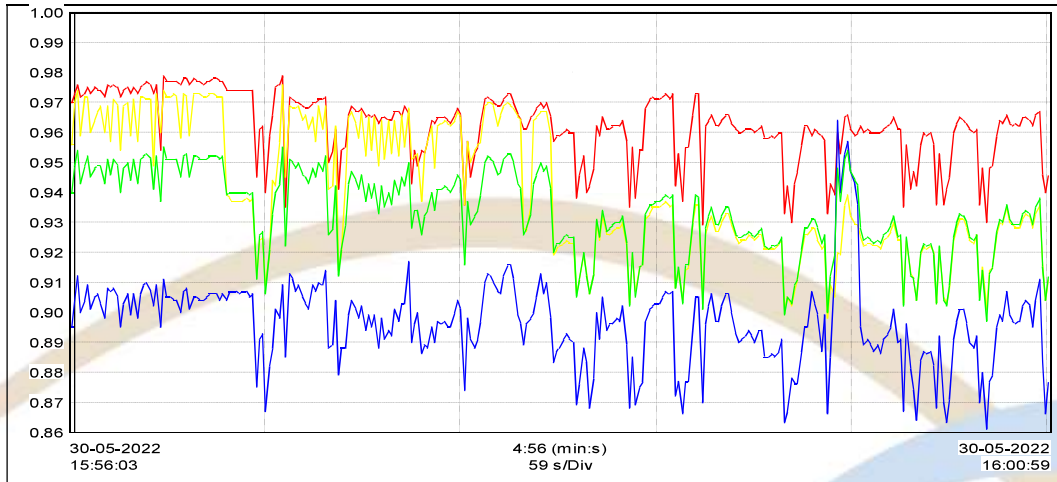

Description	Average	Min	Max
PF1	0.962	0.929	0.979
PF2	0.94	0.898	0.976
PF3	0.896	0.861	0.964
PFT	0.933	0.897	0.955

Observations and Remarks:

- The average recorded power factor is 0.933, lagging with average reactive power 7.04kVAr.
- The voltage imbalance is ~0.4%, which is within the stipulated limits.
- The average transformer loading is ~6.3%.
- It is suggested to maintain the near unity power factor.

5.2.3.7 E2-SS Street light-TR

- Voltage Ph-N

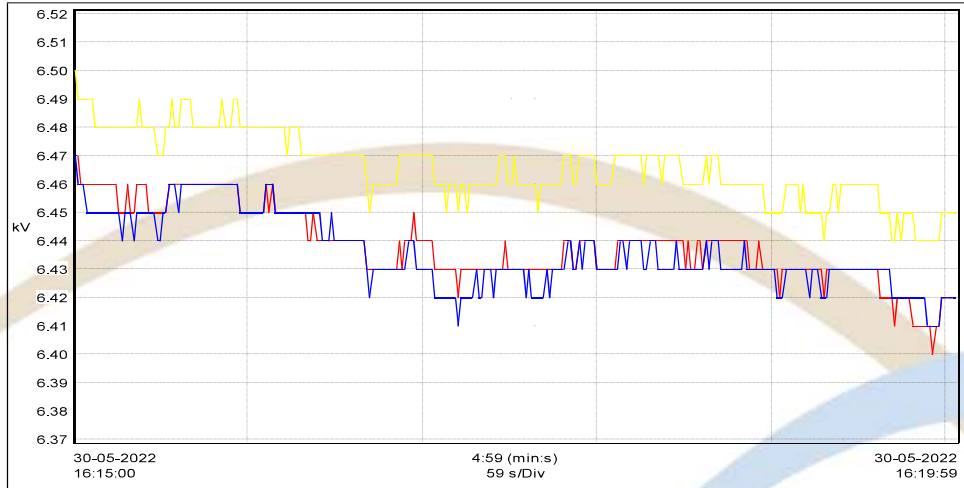

Description	Unit	Average	Min	Max
V1 rms	kV	6.438	6.37	6.49
V2 rms	kV	6.466	6.41	6.52
V3 rms	kV	6.436	6.37	6.49

- Voltage Ph-Ph

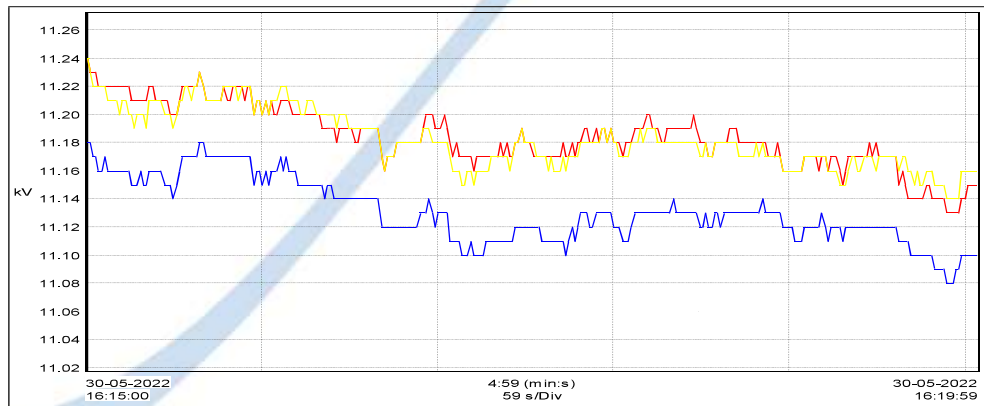

Description	Unit	Average	Min	Max
U12 rms	kV	11.18	11.08	11.27
U23 rms	kV	11.18	11.09	11.27
U31 rms	kV	11.13	11.02	11.23

• **Current**

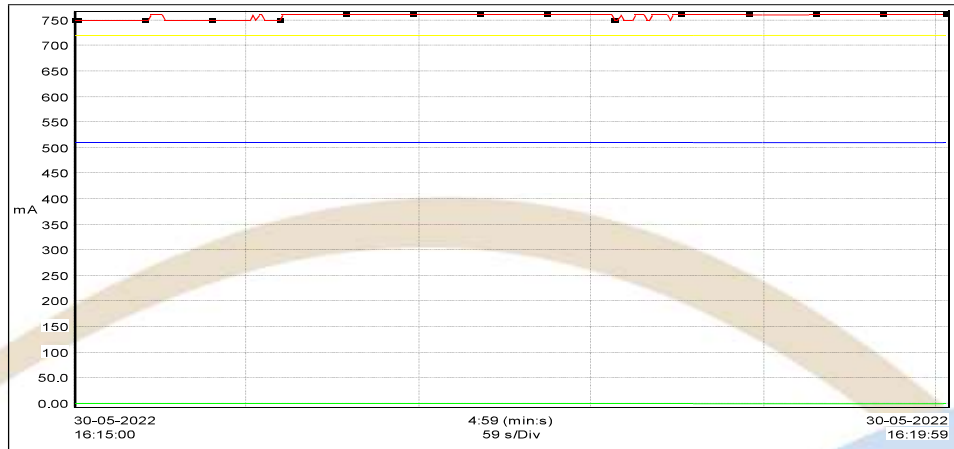

Description	Unit	Average	Min	Max
A1 rms	A	0.758	0.74	0.76
A2 rms	A	0.72	0.7	0.73
A3 rms	A	0.51	0.5	0.52
AN rms	A	0	0	0

• **Active Power**

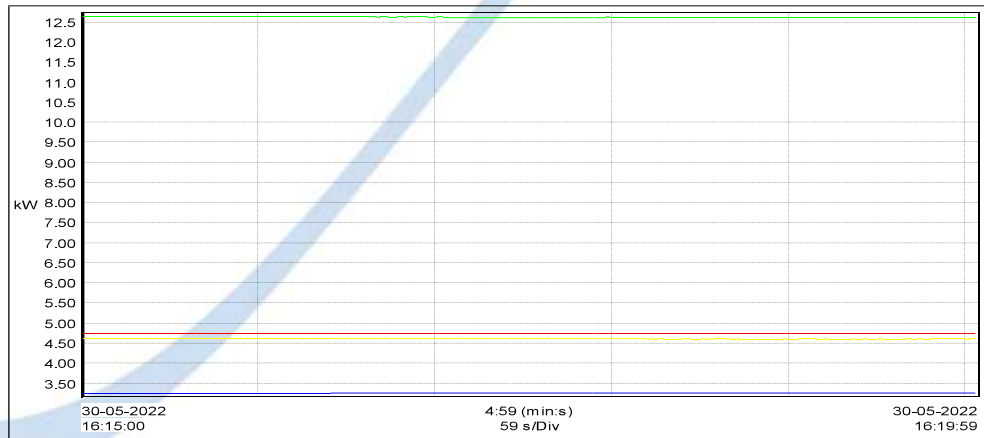

Description	Unit	Average	Min	Max
P1 (W)	kW	4.751	4.743	4.759
P2 (W)	kW	4.614	4.607	4.62
P3 (W)	kW	3.268	3.261	3.275
PT (W)	kW	12.63	12.62	12.65

- Apparent power (kVA)

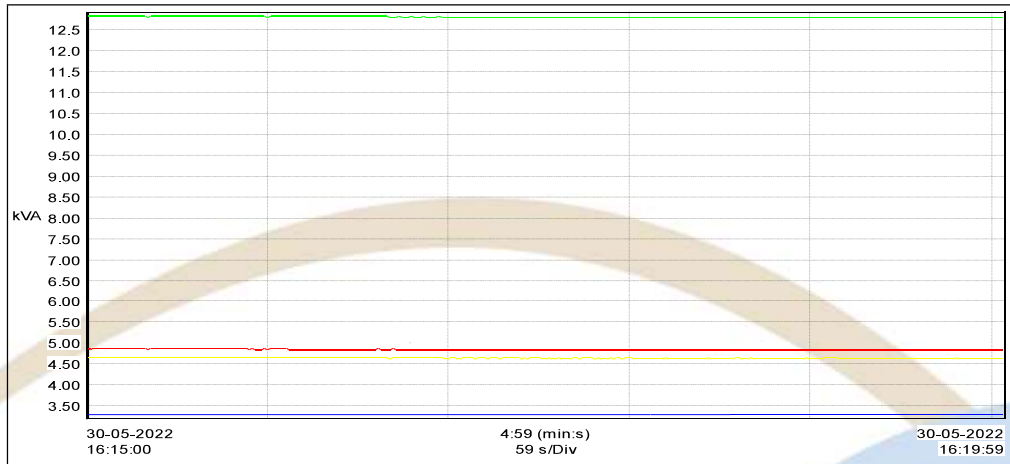

Description	Unit	Average	Min	Max
S1 (VA)	kVA	4.867	4.859	4.874
S2 (VA)	kVA	4.645	4.638	4.654
S3 (VA)	kVA	3.304	3.298	3.313
ST (VA)	kVA	12.82	12.8	12.84

- Reactive Power (kVAr)

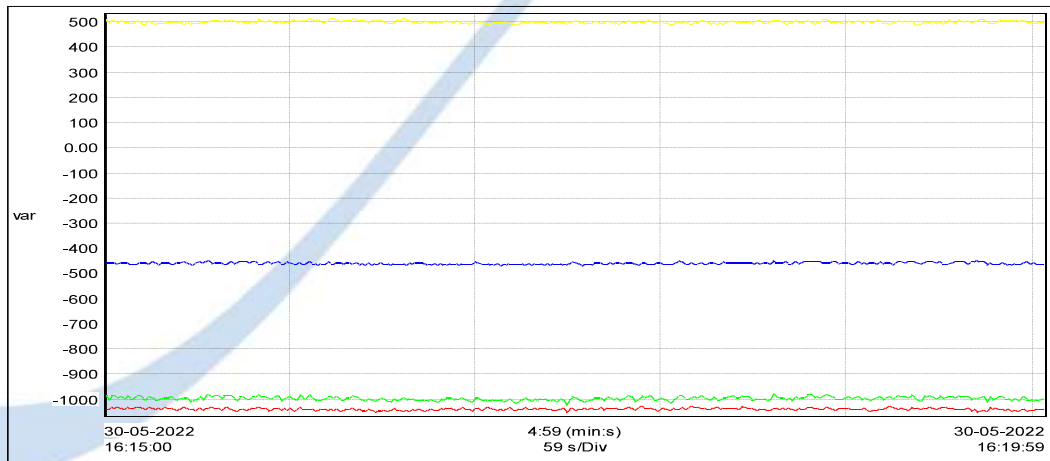

Description	Unit	Average	Min	Max
Q1 (var)	kvar	-1.038	-1.052	-1.026
Q2 (var)	var	500.7	488.1	518.2
Q3 (var)	var	-458.7	-467.9	-448.7
QT (var)	kvar	-0.996	-1.022	-0.979

- **Power factor**

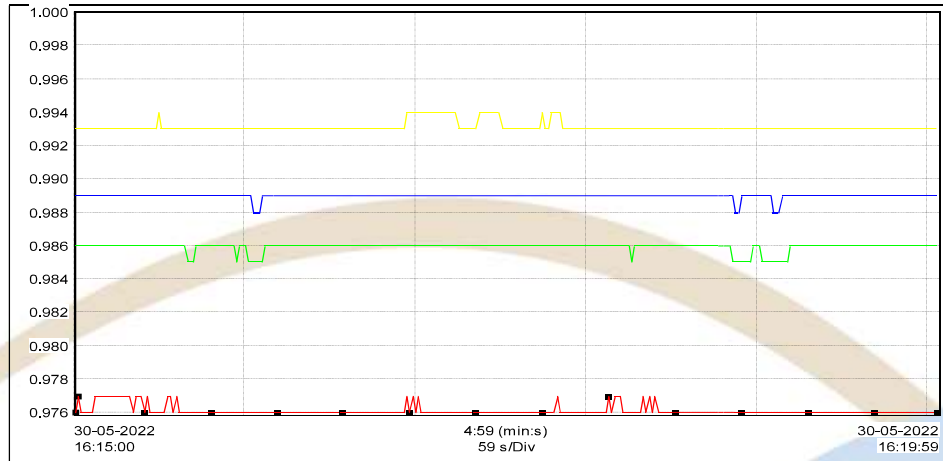

Description	Average	Min	Max
PF1	0.976	0.976	0.977
PF2	0.993	0.993	0.994
PF3	0.989	0.988	0.989
PFT	0.986	0.985	0.986

Observations and Remarks:

- The average recorded power factor is 0.986, leading with average reactive power - 0.996kVAr.
- The voltage imbalance is ~0.4%, which is within the stipulated limits.
- The average transformer loading is ~6.3%.

5.2.1 Harmonics Analysis

- The harmonics analysis was carried out by log-In the data; the details are as under.

Limits for Total Harmonic Distortion (Voltage and Current)

- IEEE-519-2014 standards stipulates that for any installation, voltage THD in the electrical network should not be more than 5% and no individual voltage harmonic component to be more than 3%.
- Limit of current harmonic distortion (THD-I) depends upon the characteristics of Transformer and ratio of Short-circuit current to Actual current ($I_{sc} \div I_{actual}$). Also, limits are laid down for various orders of Harmonics. Allowable current harmonics:

Current distortion limits for system rated 120V through 69kV.

Maximum Harmonic Current Distortion in Percent of I_L						
Individual Harmonic Order (Odd Harmonics)						
I_{sc}/I_L	<11	$11 \leq h < 17$	$17 \leq h < 23$	$23 \leq h < 35$	$35 \leq h$	TDD
<20*	4.0	2.0	1.5	0.6	0.3	5.0
20<50	7.0	3.5	2.5	1.0	0.5	8.0
50<100	10.0	4.5	4.0	1.5	0.7	12.0
100<1000	12.0	5.5	5.0	2.0	1.0	15.0
>1000	15.0	7.0	6.0	2.5	1.4	20.0

Even harmonics are limited to 25% of the odd harmonic limits above.

Current distortions that result in a DC offset, e.g. half-wave converters, are not allowed.

**All power generation equipment's is limited to these values of current distortion, regardless of actual I_{sc}/I_L*

Where
 I_{sc} = maximum short-current at PCC
 I_L = maximum demand load current (fundamental frequency component) at PCC
 TDD = Total demand distortion (RSS). Harmonic current distortion in % of maximum demand Load current (15- or 30-min demand).
 PCC = Point of common coupling.

5.2.1.1 Total Harmonics Distortion- Main incomer-50MVA

• Voltage P-N

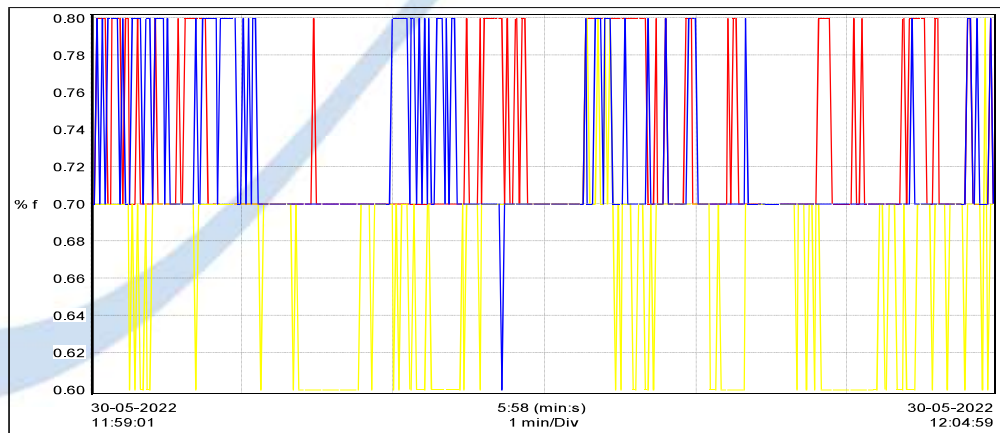

Description	Unit	Average	Minimum	Maximum
V1 THDf	% f	0.726	0.7	0.8
V2 THDf	% f	0.669	0.6	0.8
V3 THDf	% f	0.721	0.6	0.8

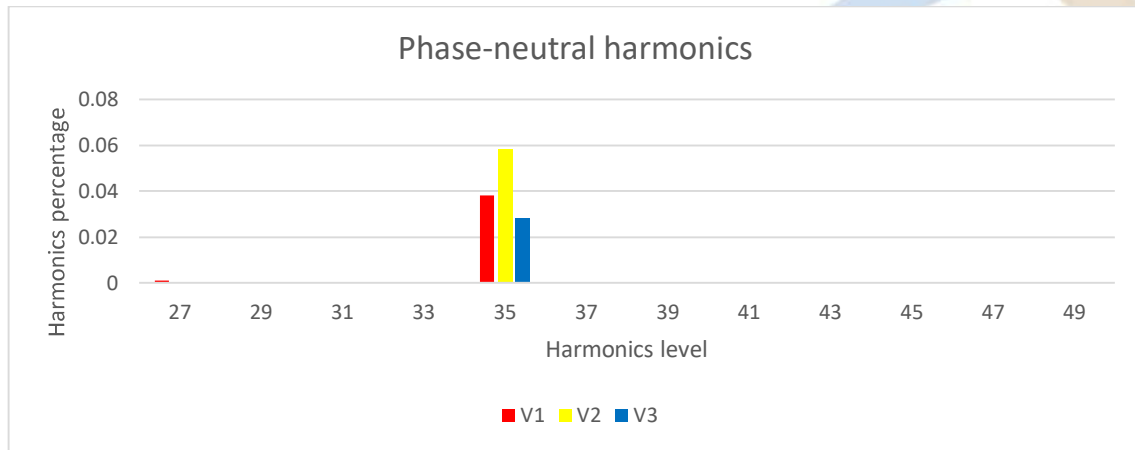
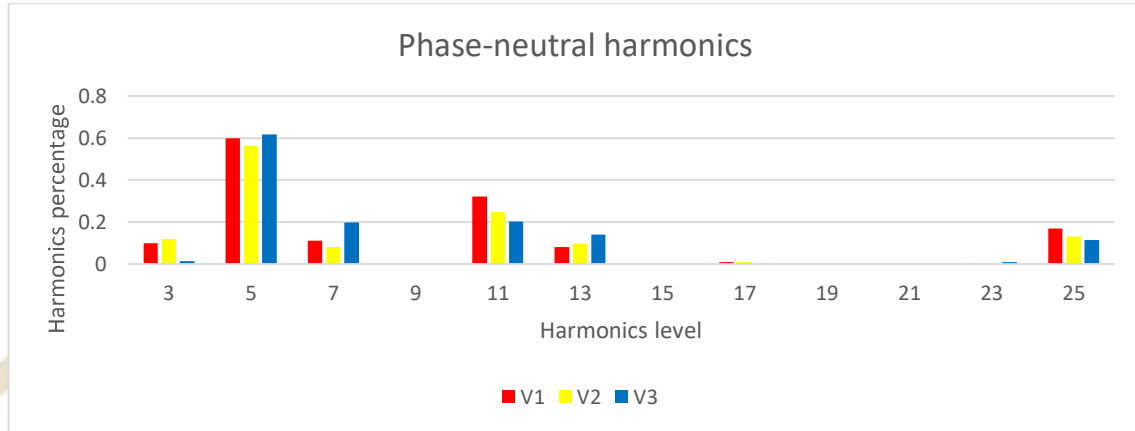

Observations:

- The total harmonic distortion and individual odd harmonics distortion – voltage is within the stipulated limit, as per IEEE STD 519-2014.

• **Current (%)**

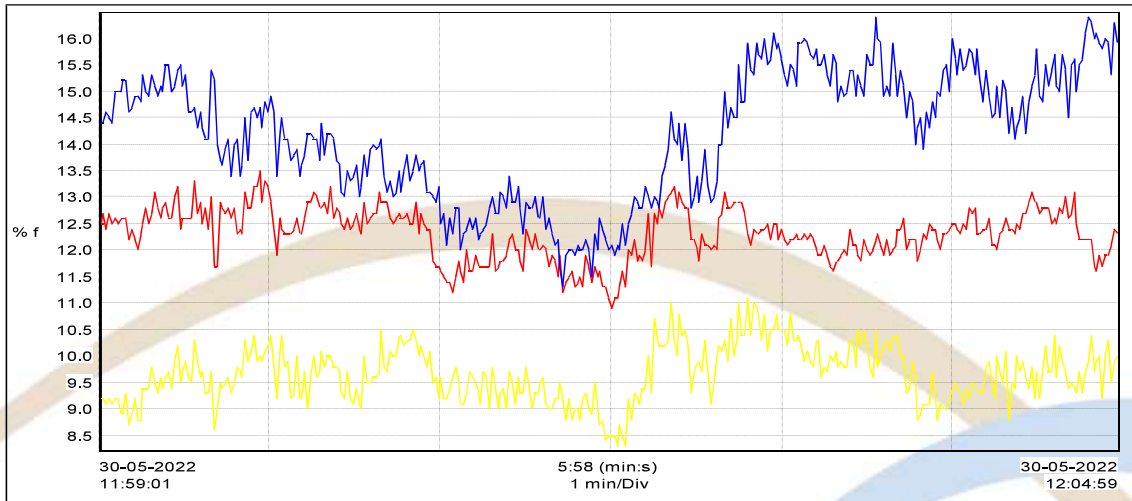

Description	Unit	Average	Minimum	Maximum
A1 rms	% f	14.13	12	15.2
A2 rms	% f	12.67	11.2	13.6
A3 rms	% f	11.89	10.4	12.8

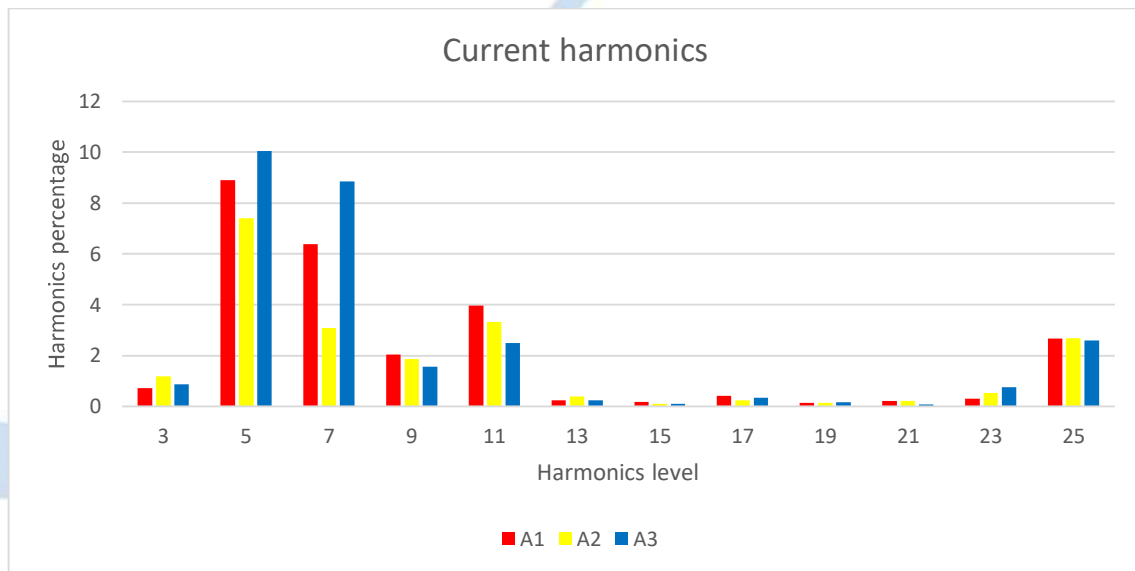

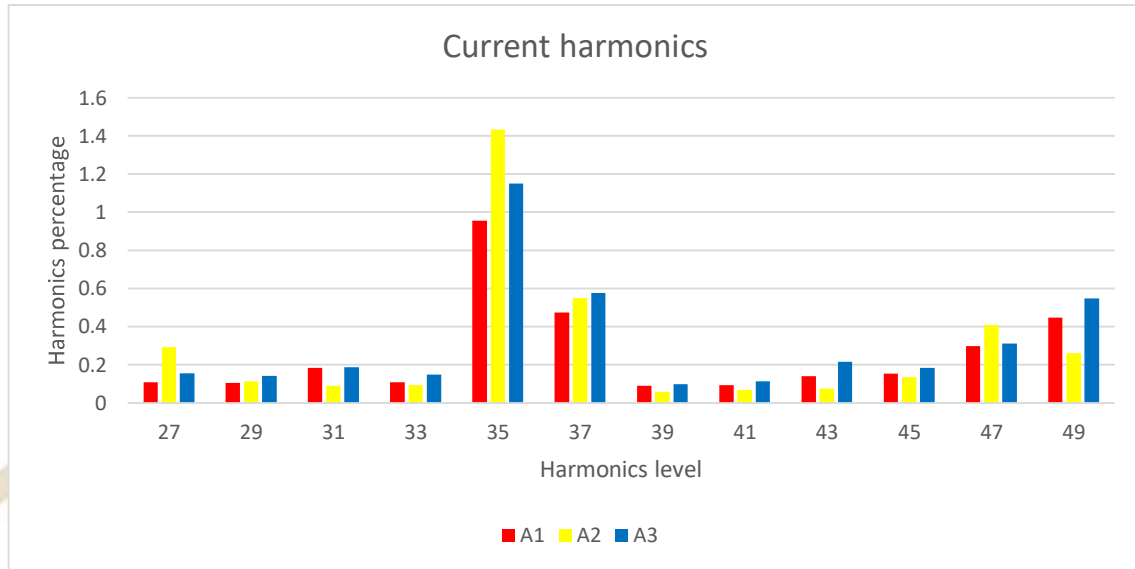

Observations:

- Here, $I_{sc}/I_L = 1000 <$
- The total harmonic distortion – current is within the stipulated limit 20%, as per IEEE STD 519-2014.
- The 35th harmonic distortion – current is higher than the stipulated limit 1.4% and remaining odd harmonic distortion-current within the stipulated limit, as per IEEE STD 519-2014.

5.2.1.2 Total Harmonics Distortion- Station Transformer 500kVA

• Voltage P-N

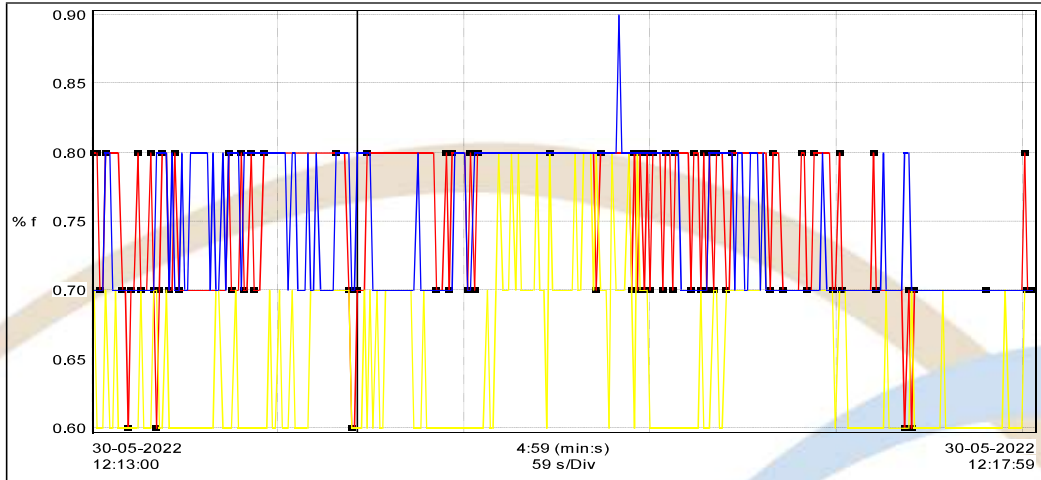

Description	Unit	Average	Min	Max
V1 THDf	% f	0.753	0.6	0.8
V2 THDf	% f	0.65	0.6	0.8
V3 THDf	% f	0.746	0.7	0.9

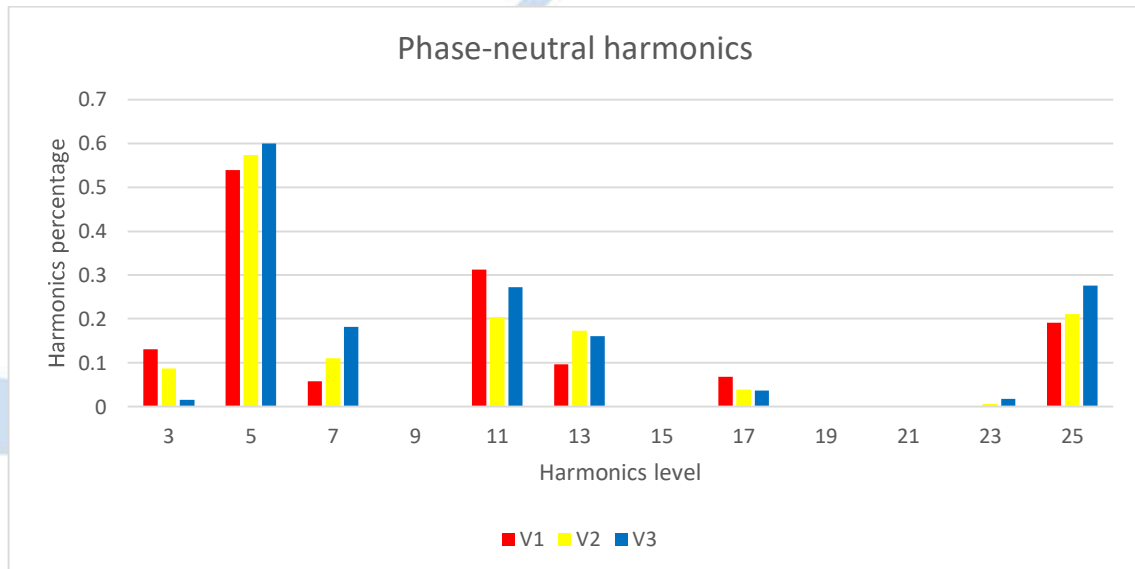

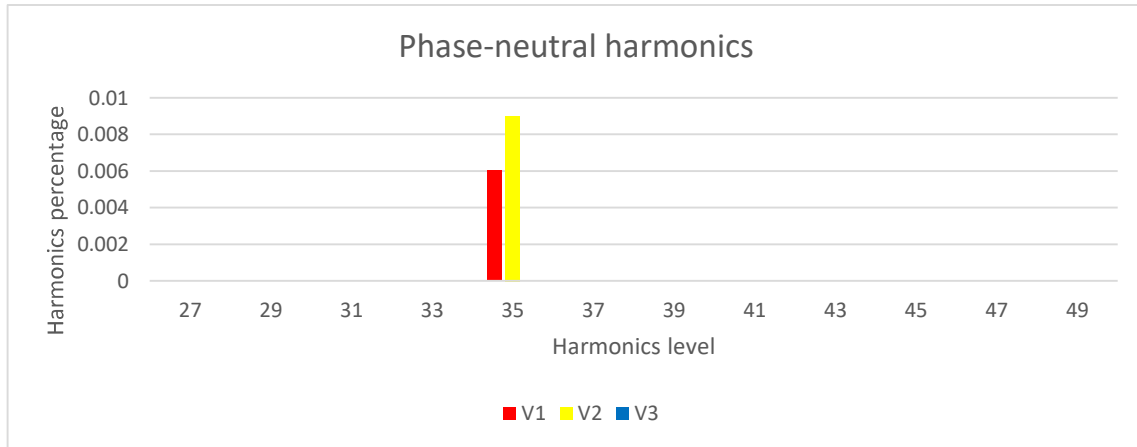

Observations:

- The total harmonic distortion and individual odd harmonics distortion – voltage is within the stipulated limit, as per IEEE STD 519-2014.

- Current (%)**

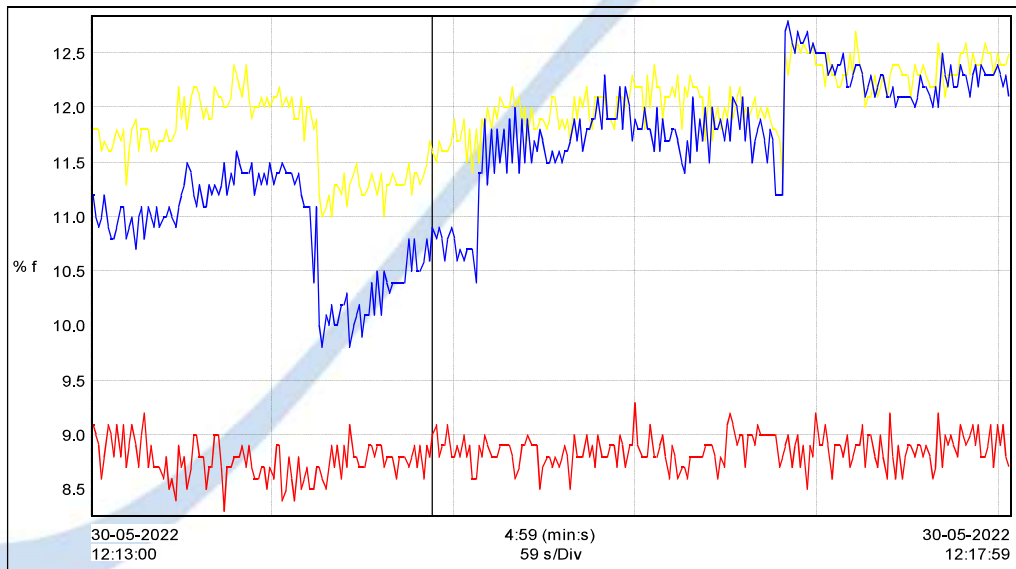

Description	Unit	Average	Min	Max
A1 THDf	% f	8.826	8.3	9.3
A2 THDf	% f	11.96	11	12.7
A3 THDf	% f	11.51	9.8	12.8

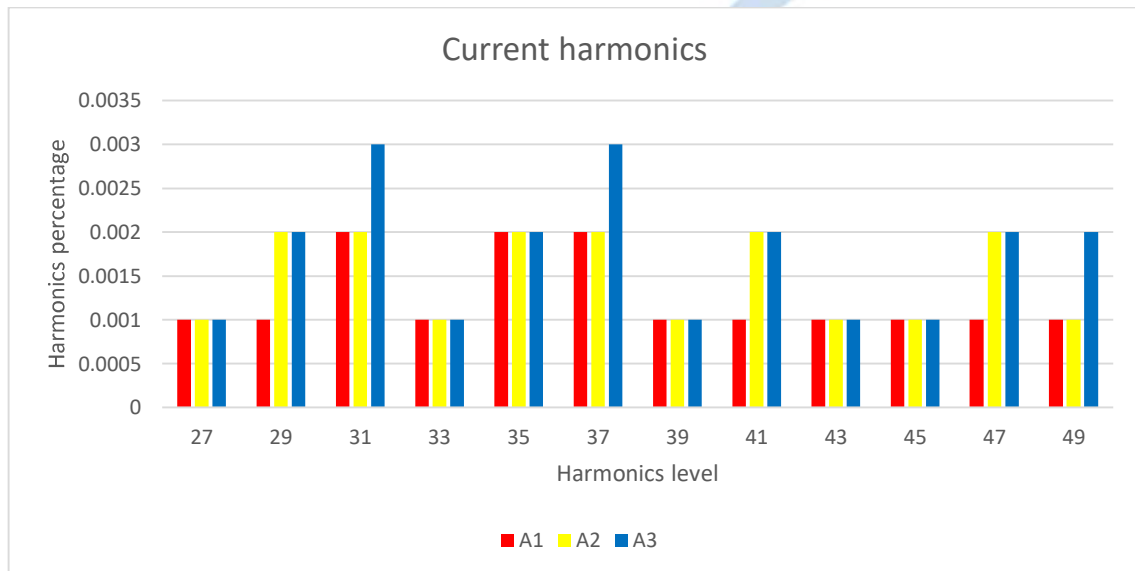
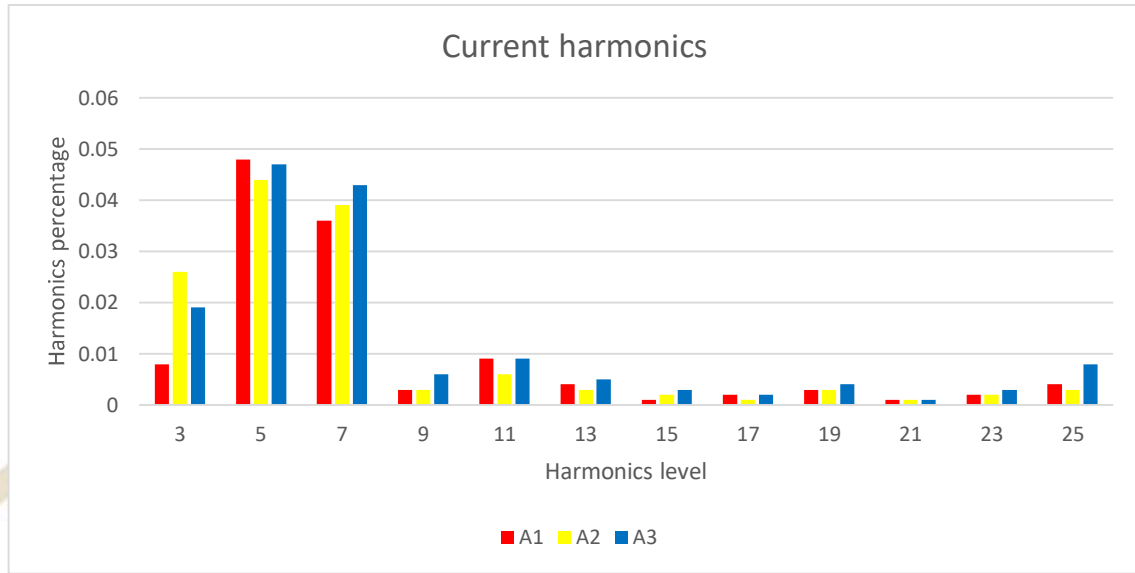

Observations:

- Here, $I_{sc}/I_L = 1000 <$
- The total harmonic distortion – current is within the stipulated limit of 20%, as per IEEE STD 519-2014.
- The individual odd harmonic distortion – current upto 49th order is within the stipulated limit, as per IEEE STD 519-2014.

5.2.1.3 Total Harmonics Distortion- Main incomer-E2-SS I/C-1

• Voltage P-N

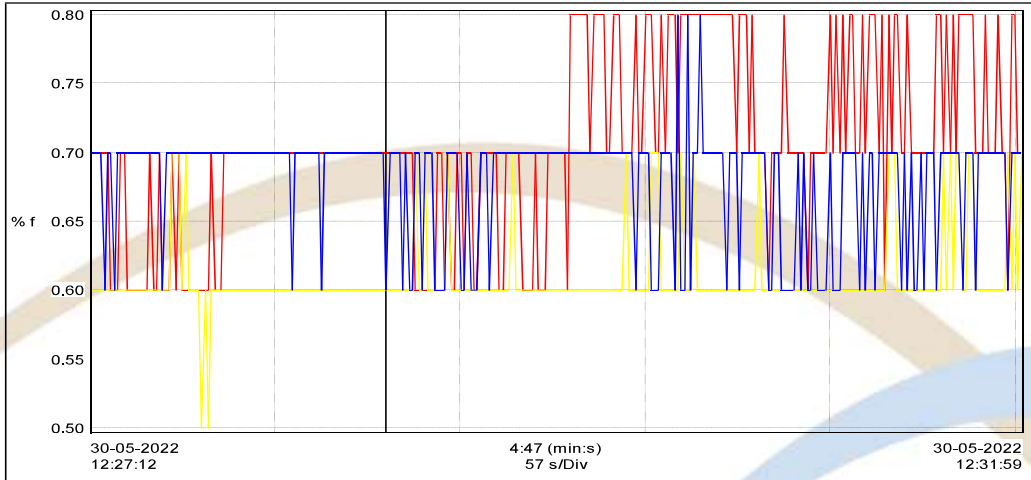

Description	Unit	Average	Min	Max
V1 THDf	% f	0.705	0.6	0.8
V2 THDf	% f	0.609	0.5	0.7
V3 THDf	% f	0.681	0.6	0.8

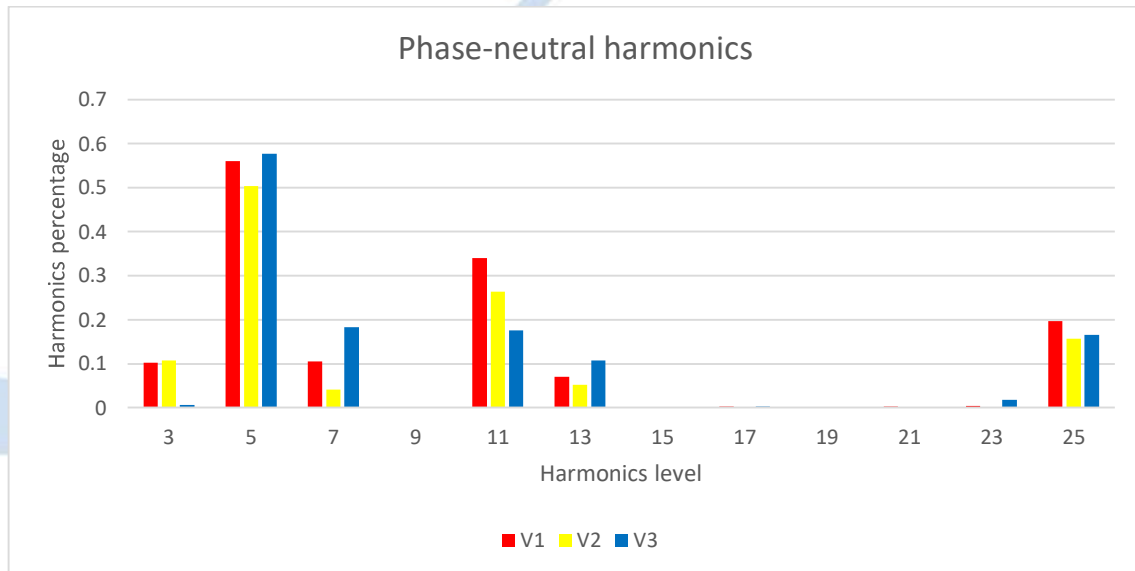

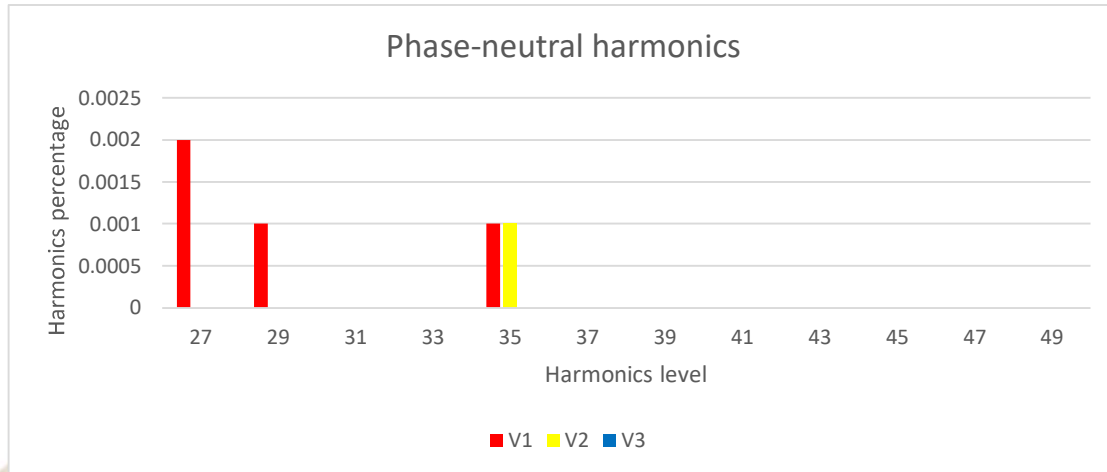

Observations:

- The total harmonic distortion and individual odd harmonics distortion – voltage is within the stipulated limit, as per IEEE STD 519-2014.
- Current (%)**

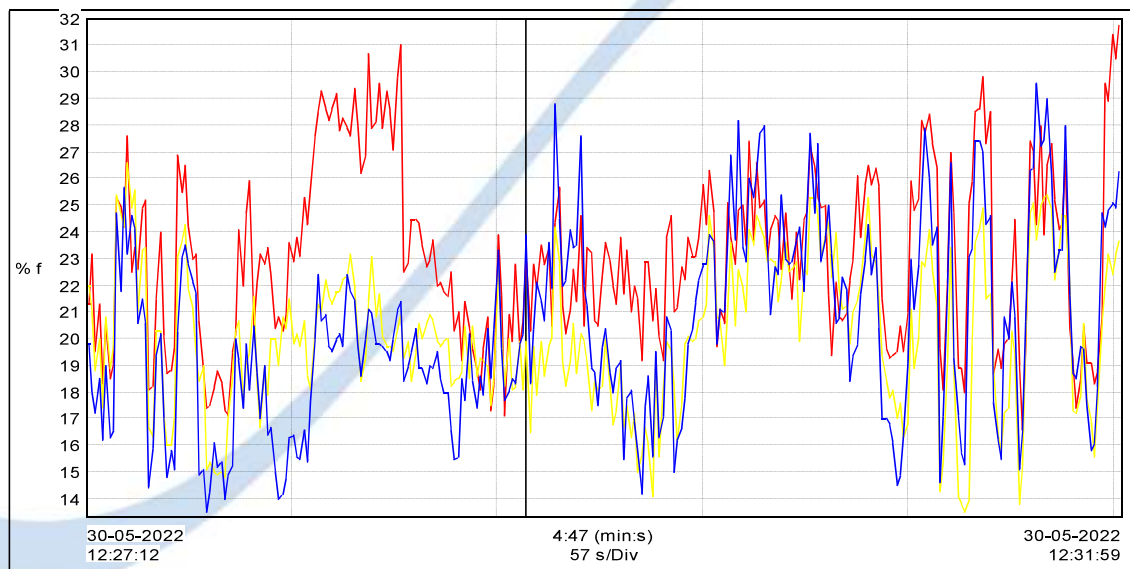

Description	Unit	Average	Min	Max
A1 THDf	% f	23.14	16.6	31.8
A2 THDf	% f	20.16	13.5	26.6
A3 THDf	% f	20.38	13.5	29.6

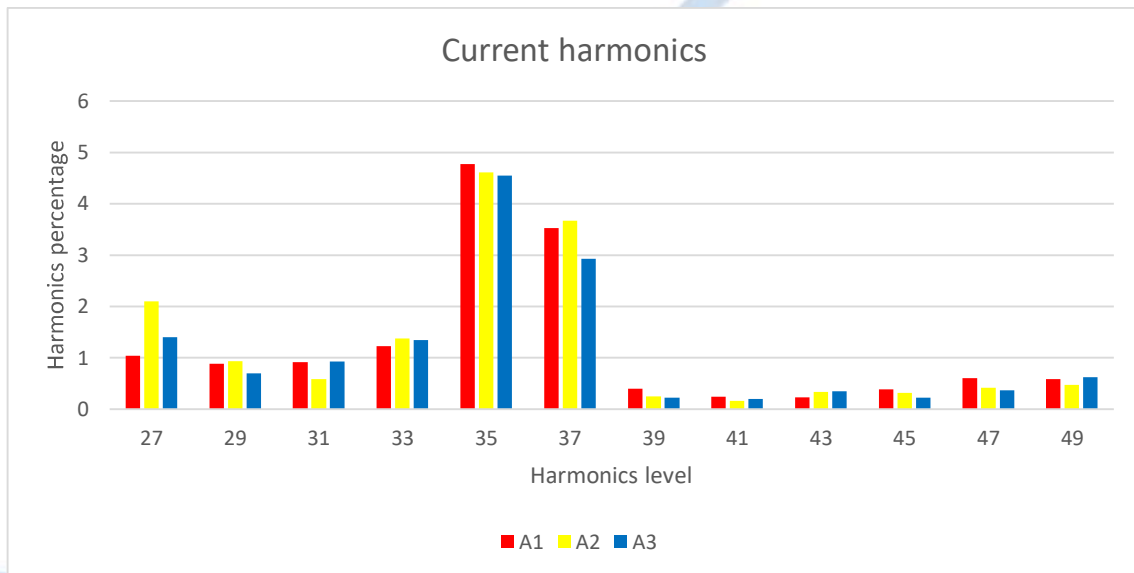
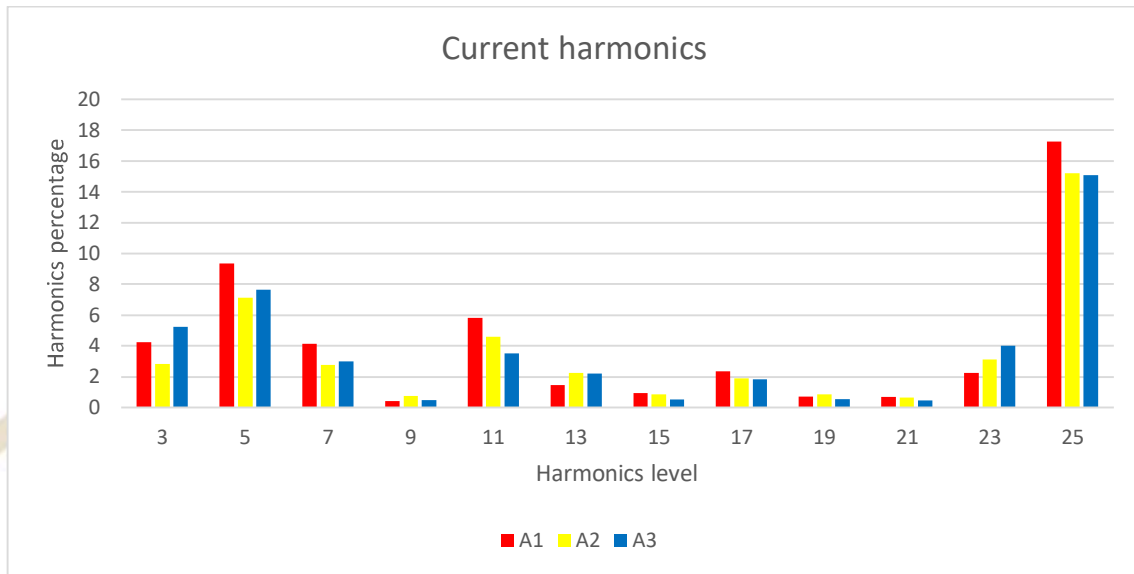

Observations:

- Here, $I_{sc}/I_L = 1000 <$
- The total harmonic distortion – current is higher than the stipulated limit of 20%, as per IEEE STD 519-2014.

- The 35th and 37th harmonic distortion – current is higher than the stipulated limit of 1.4% and remaining odd harmonic distortion -current upto 49th order is within the stipulated limit, as per IEEE STD 519-2014.

5.2.1.4 Total Harmonics Distortion- E1-SS I/C-1

• Voltage P-N

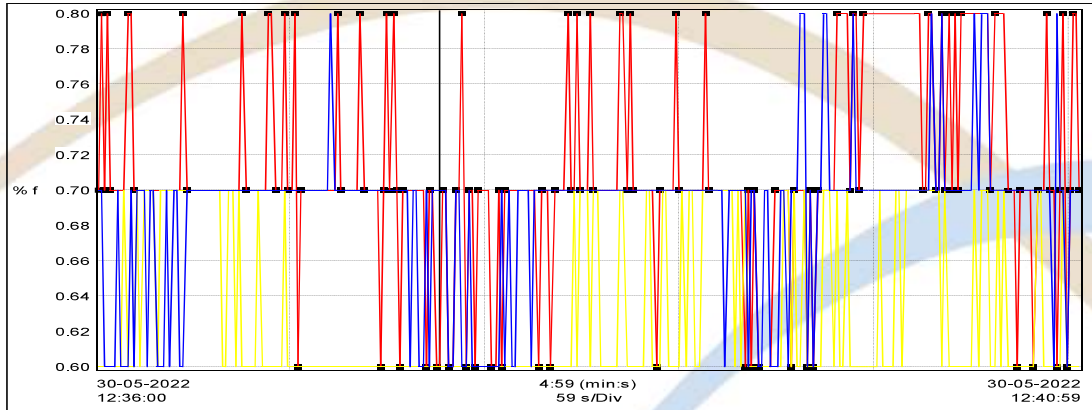

Description	Unit	Average	Min	Max
V1 THDf	% f	0.713	0.6	0.8
V2 THDf	% f	0.63	0.6	0.7
V3 THDf	% f	0.688	0.6	0.8

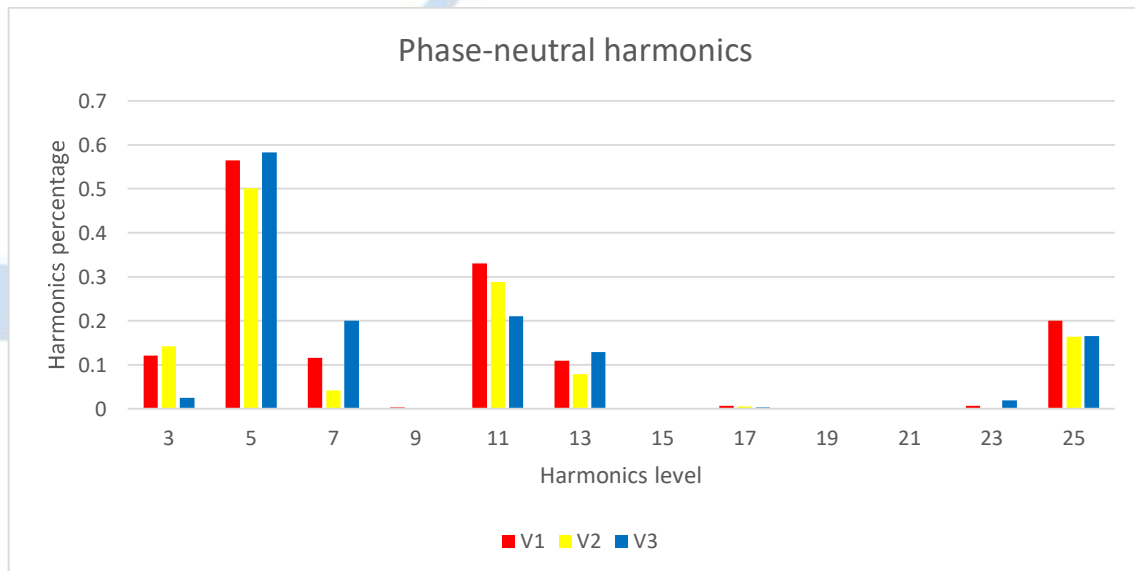

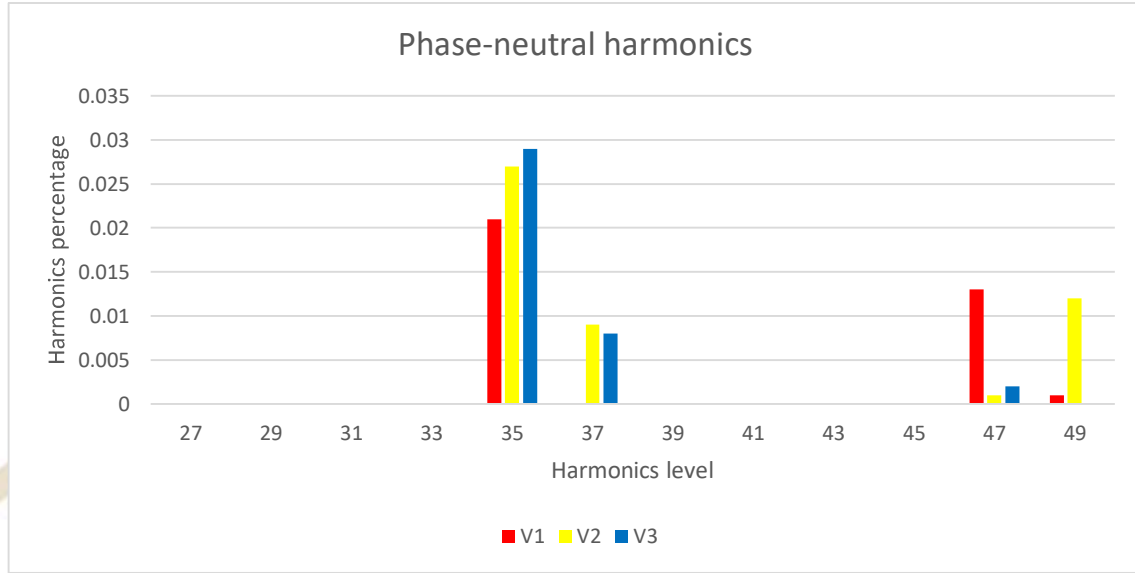

Observations:

- The total harmonic distortion and individual odd harmonics distortion – voltage is within the stipulated limit, as per IEEE STD 519-2014.
- **Current (%)**

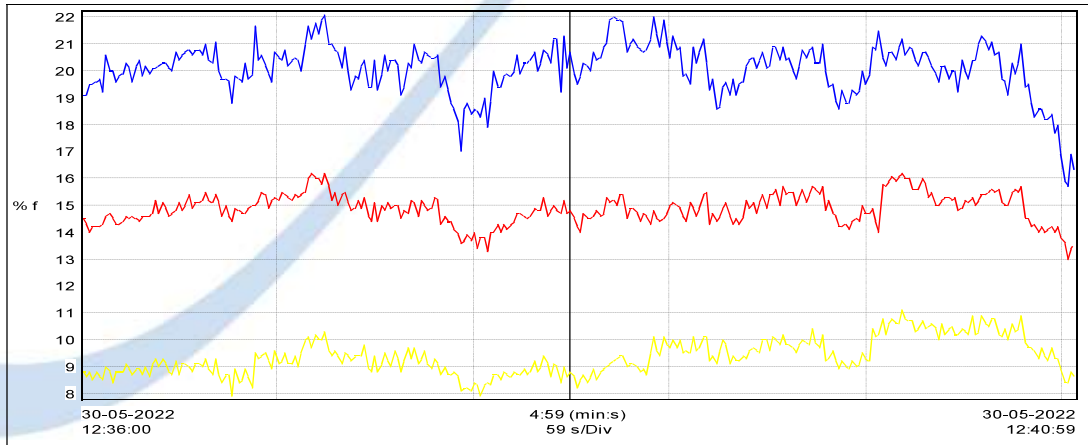

Description	Unit	Average	Min	Max
A1 THDf	% f	14.87	13	16.2
A2 THDf	% f	9.36	7.9	11.1
A3 THDf	% f	20.08	15.7	22.1

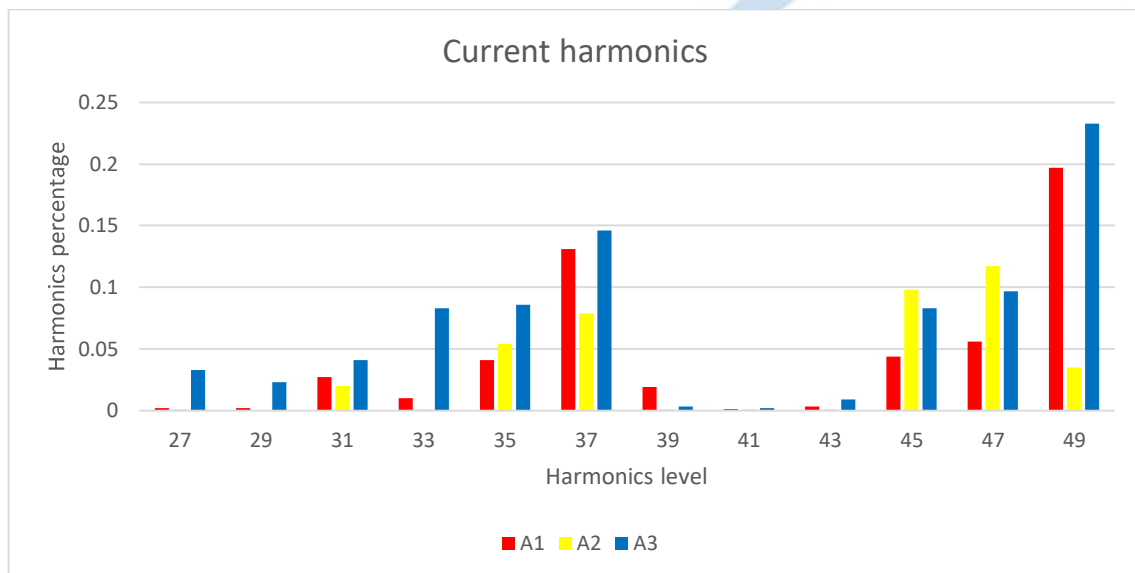
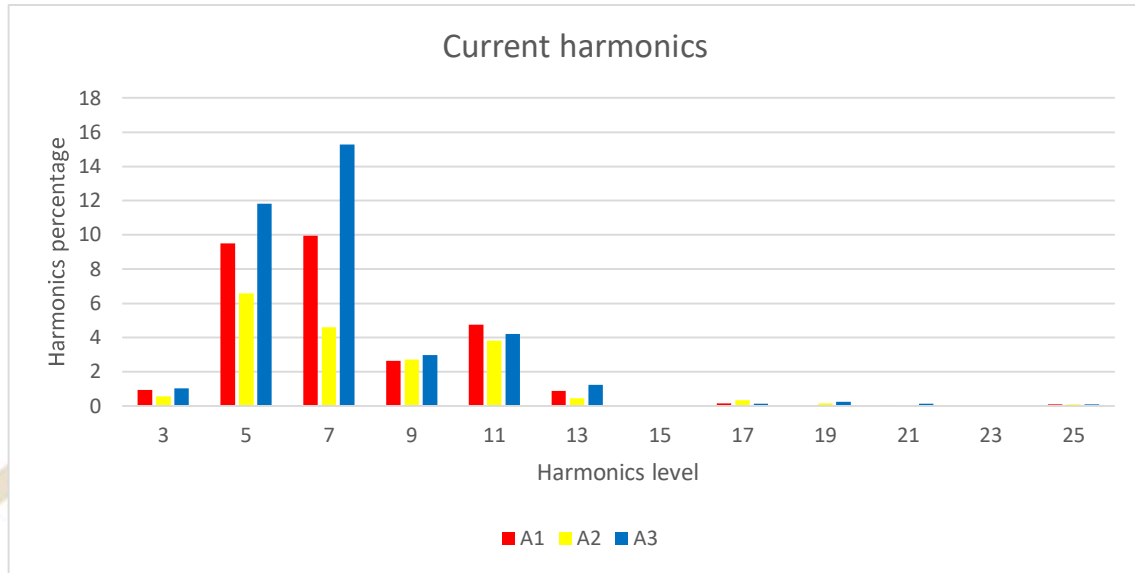

Observations:

- Here, $I_{sc}/I_L = 1000 <$
- The total harmonic distortion – current is around stipulated limit of 20%, as per IEEE STD 519-2014.
- The 7th harmonic distortion – current, is higher than the stipulated limit of 15% and remaining odd harmonic distortion -current upto 49th order is within the stipulated limit, as per IEEE STD 519-2014.

5.2.1.5 Total Harmonics Distortion- E2-SS I/C-2

• Voltage P-N

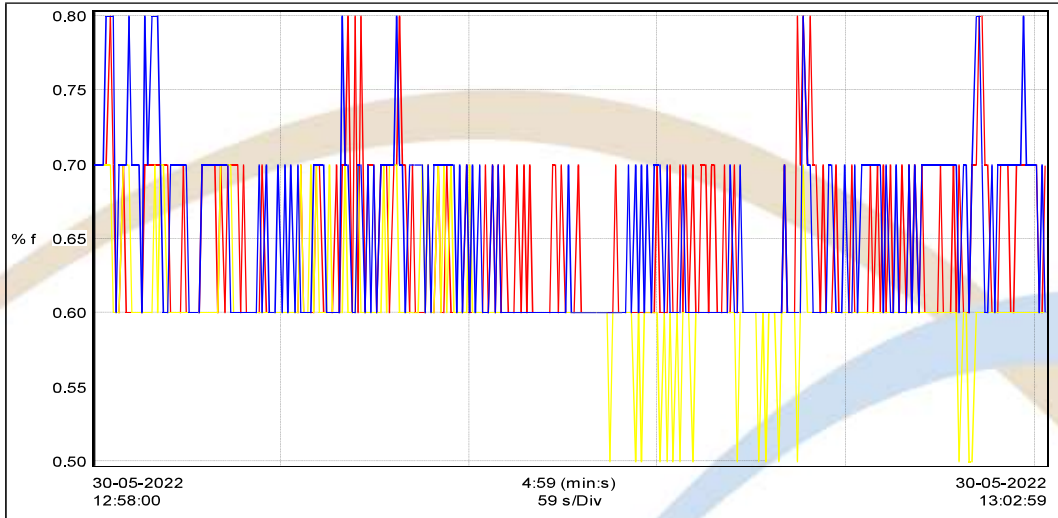

Description	Unit	Average	Min	Max
V1 THDf	% f	0.642	0.6	0.8
V2 THDf	% f	0.606	0.5	0.7
V3 THDf	% f	0.652	0.6	0.8

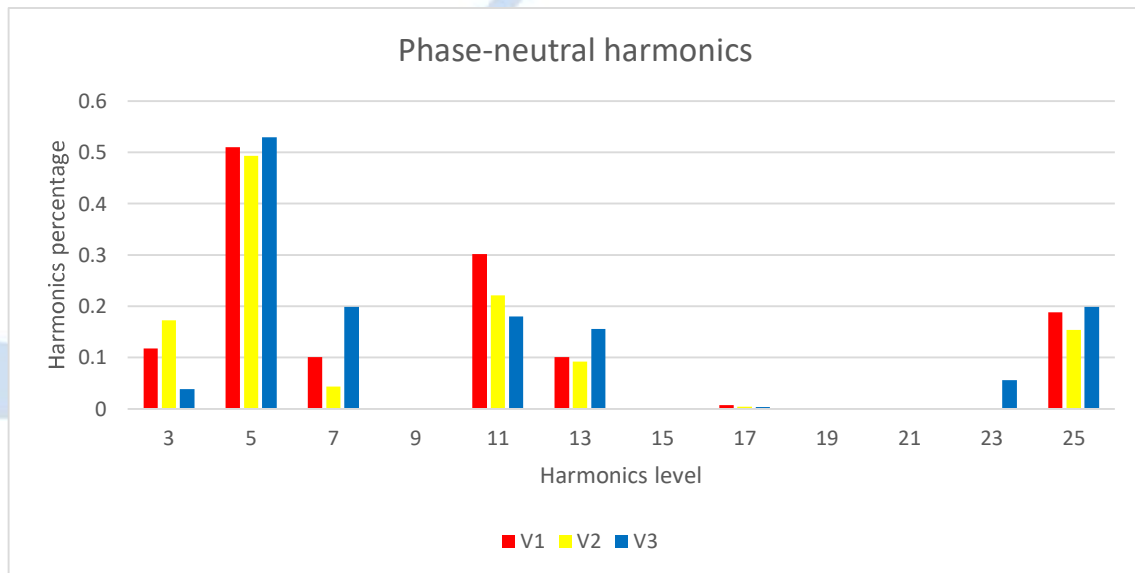

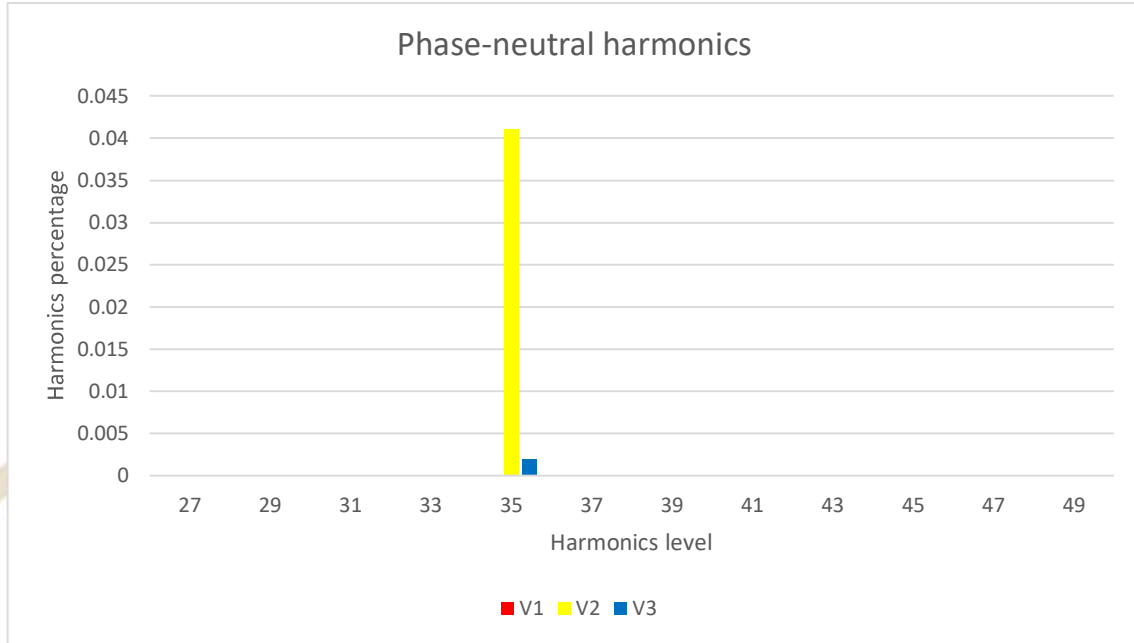

Observations:

- The total harmonic distortion and individual odd harmonics distortion – voltage is within the stipulated limit, as per IEEE STD 519-2014.
- **Current (%)**

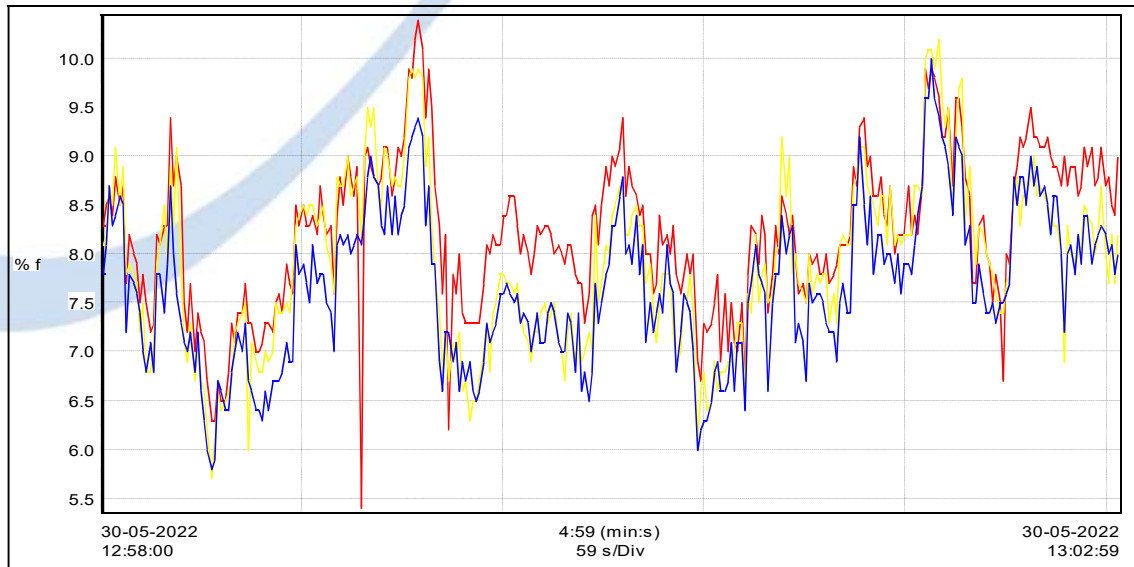

Description	Unit	Average	Min	Max
A1 THDf	% f	8.22	5.4	10.4
A2 THDf	% f	7.907	5.7	10.2
A3 THDf	% f	7.669	5.8	10

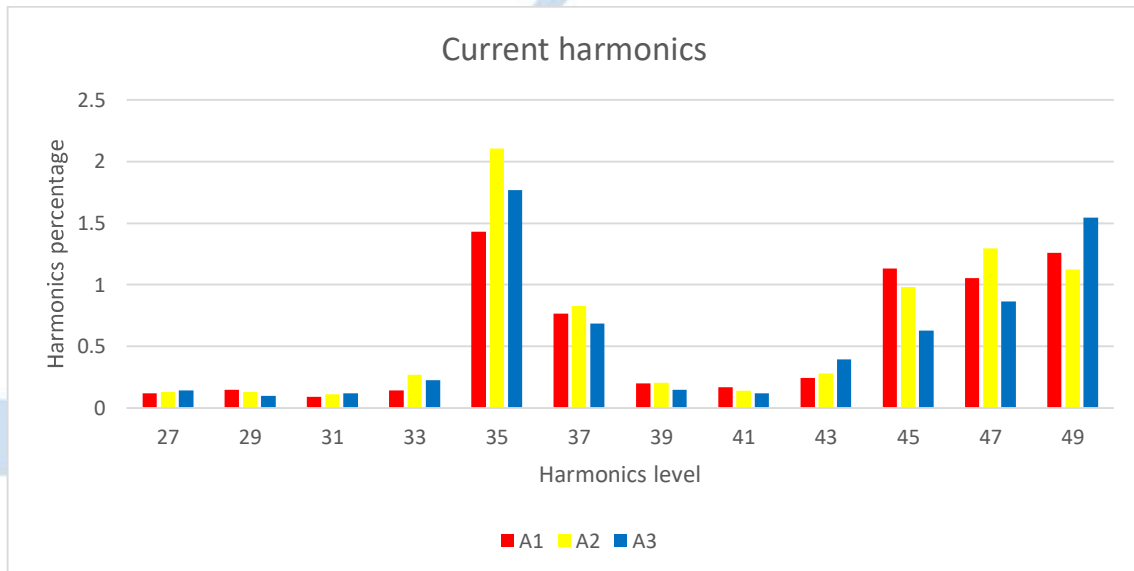
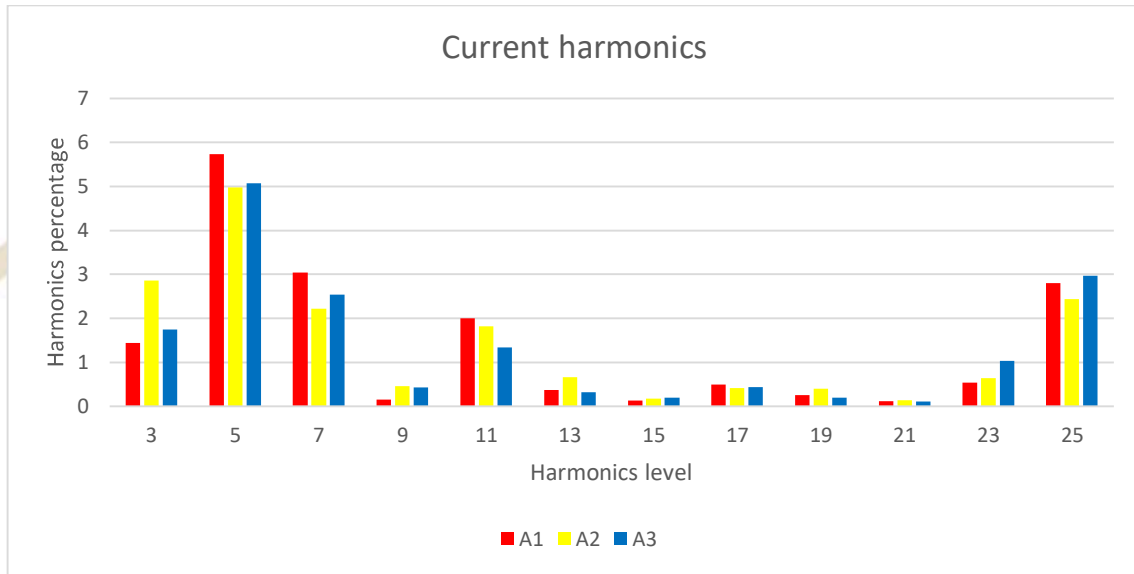

Observations:

- Here, $I_{sc}/I_L = 1000 <$
- The total harmonic distortion – current is within the stipulated limit 20%, as per IEEE STD 519-2014.
- The 35th & 49th harmonic distortion – current is higher than the stipulated limit 1.4% and remaining odd harmonic distortion-current within the stipulated limit, as per IEEE STD 519-2014.

5.2.1.6 Total Harmonics Distortion-E1-SS Station TR-1

• Voltage P-N

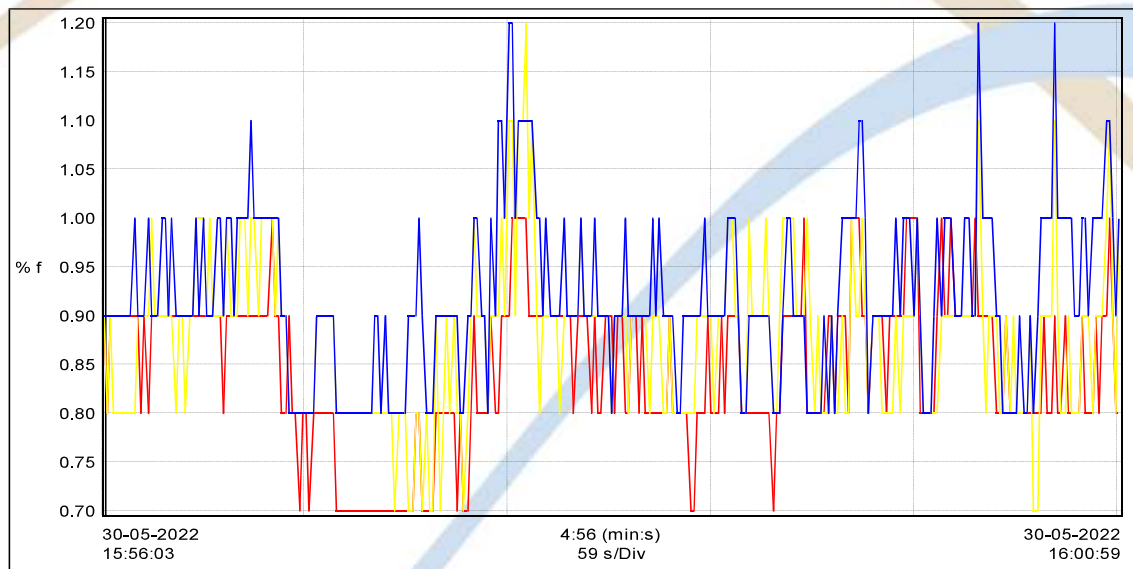

Description	Unit	Average	Min	Max
V1 THDf	% f	0.844	0.7	1
V2 THDf	% f	0.877	0.7	1.2
V3 THDf	% f	0.92	0.8	1.2

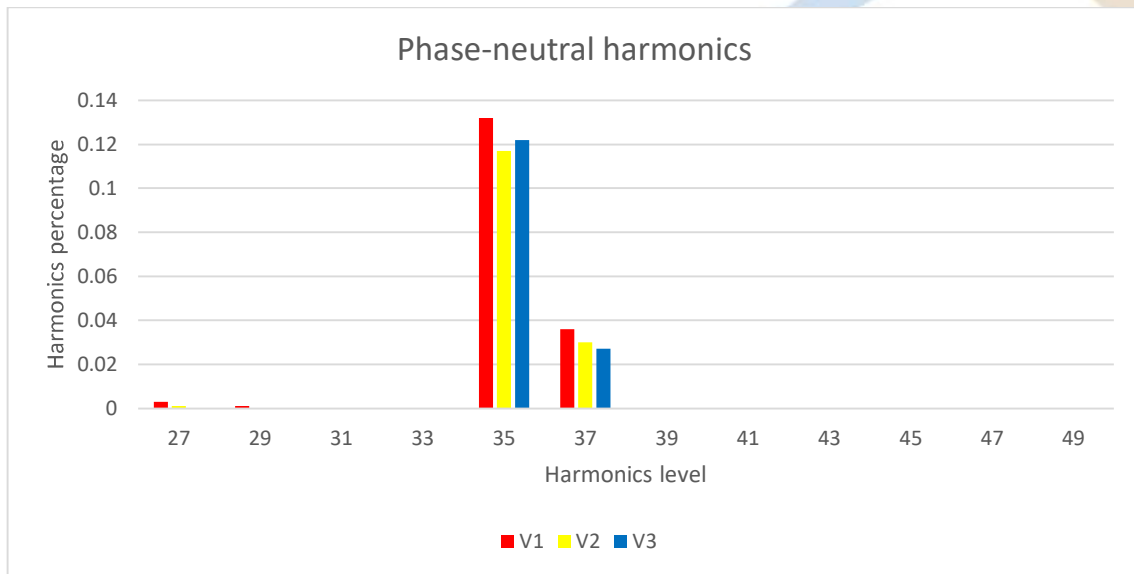
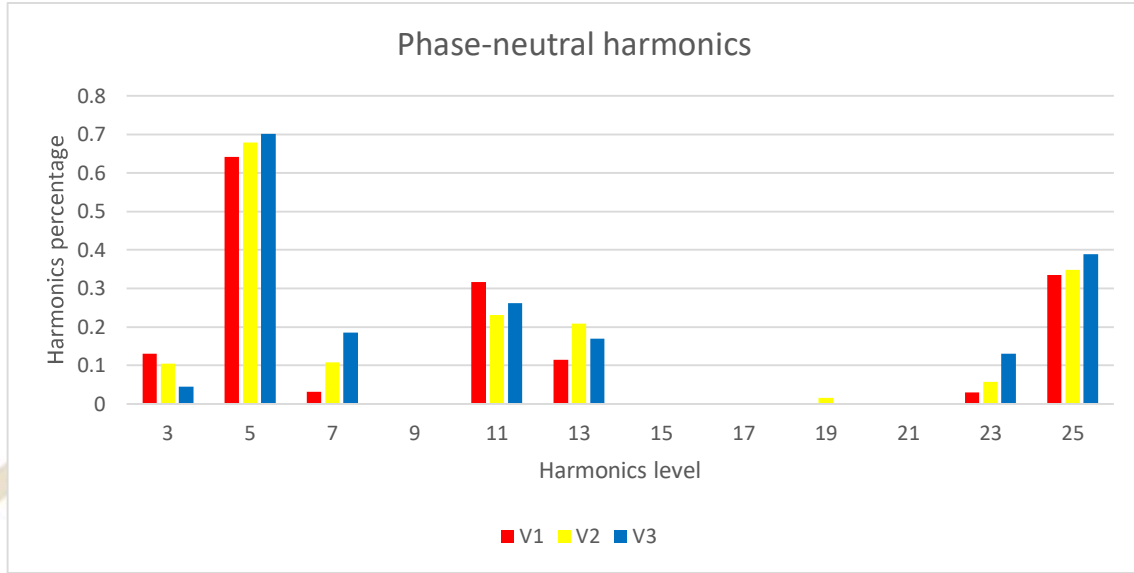

Observations:

- The total harmonic distortion and individual odd harmonics distortion – voltage is within the stipulated limit, as per IEEE STD 519-2014.

• **Current (%)**

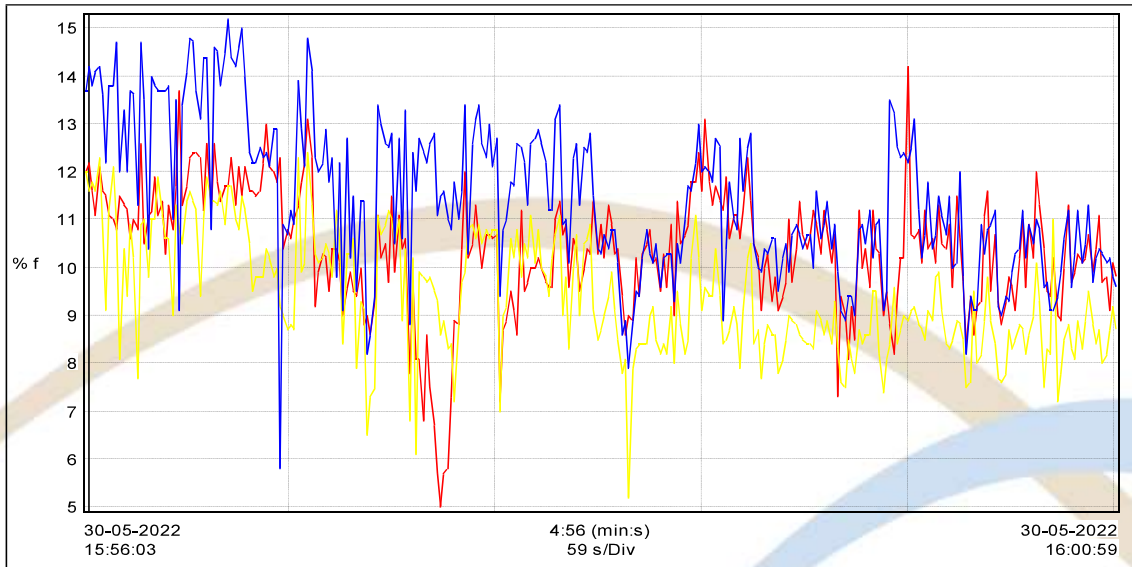

Description	Unit	Average	Min	Max
A1 THDf	% f	10.38	5	14.2
A2 THDf	% f	9.413	5.2	12.4
A3 THDf	% f	11.46	5.8	15.2

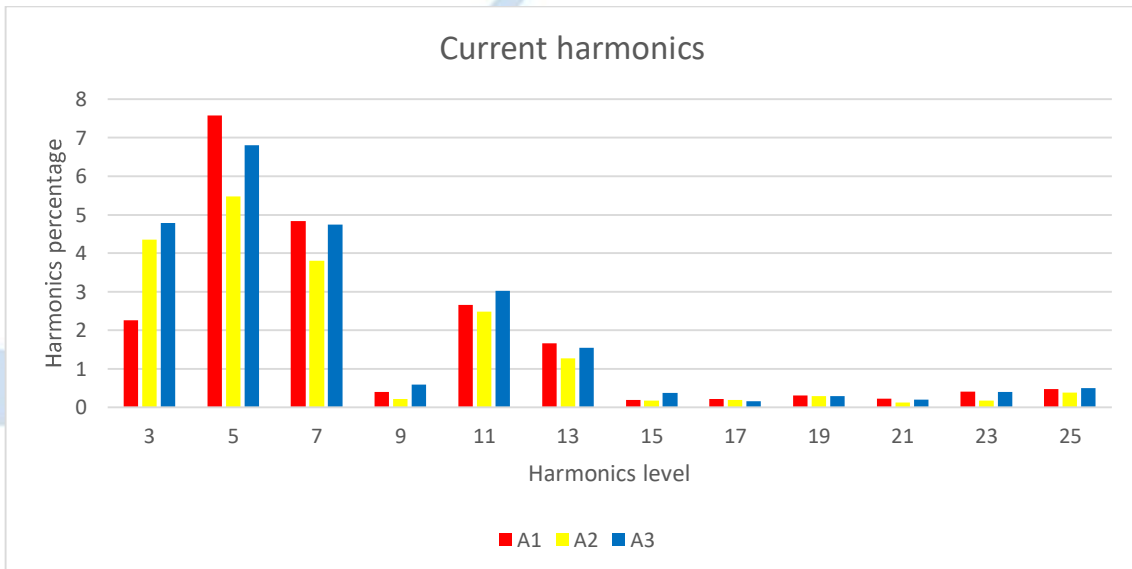

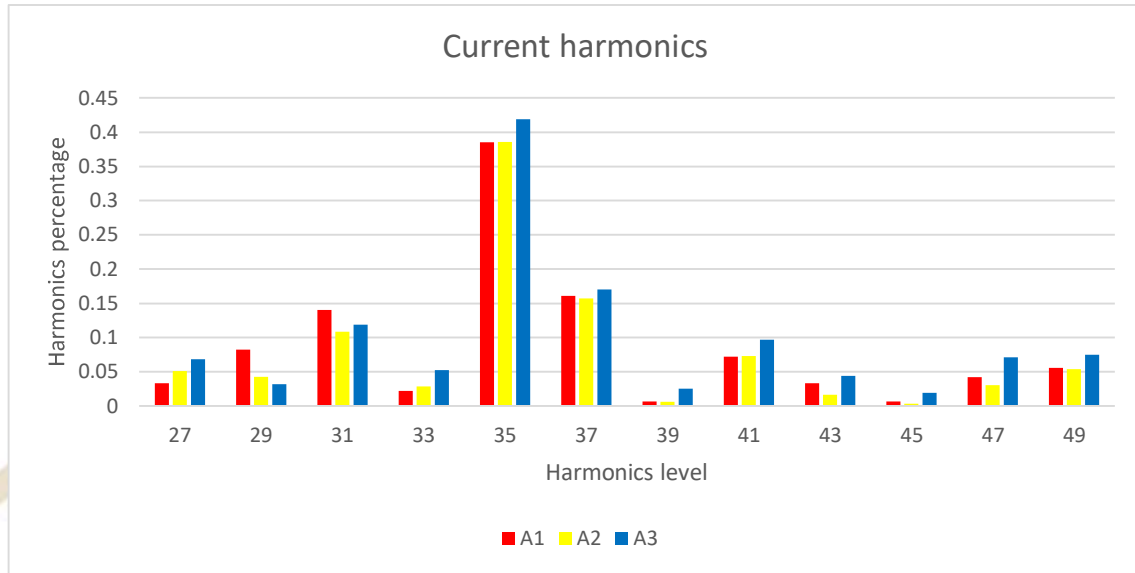

Observations:

- Here, $I_{sc}/I_L = 1000 <$
- The total harmonic distortion – current is within the stipulated limit 20%, as per IEEE STD 519-2014.
- The odd harmonic distortion – current upto the 49th order within the stipulated limit 1.4% as per IEEE STD 519-2014.

5.2.1.7 Total Harmonics Distortion-E2-SS Street Light TR

• Voltage P-N

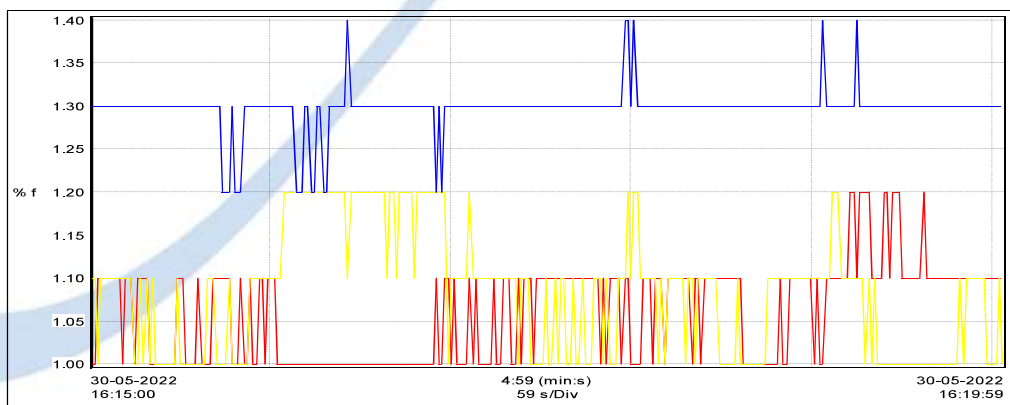

Description	Unit	Average	Min	Max
V1 THDf	% f	1.061	1	1.2
V2 THDf	% f	1.084	1	1.2
V3 THDf	% f	1.297	1.2	1.4

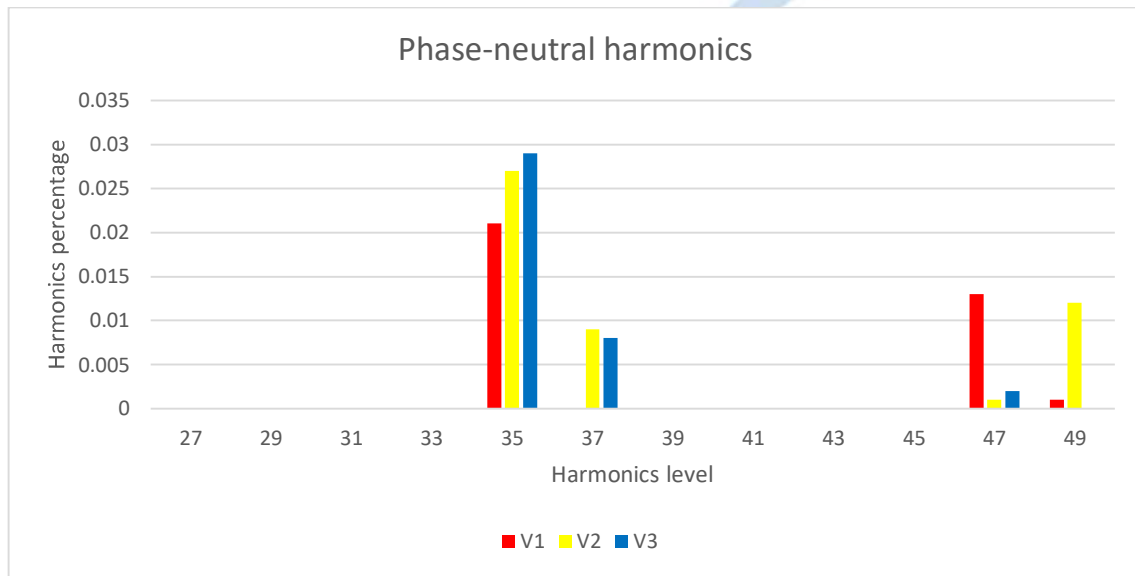
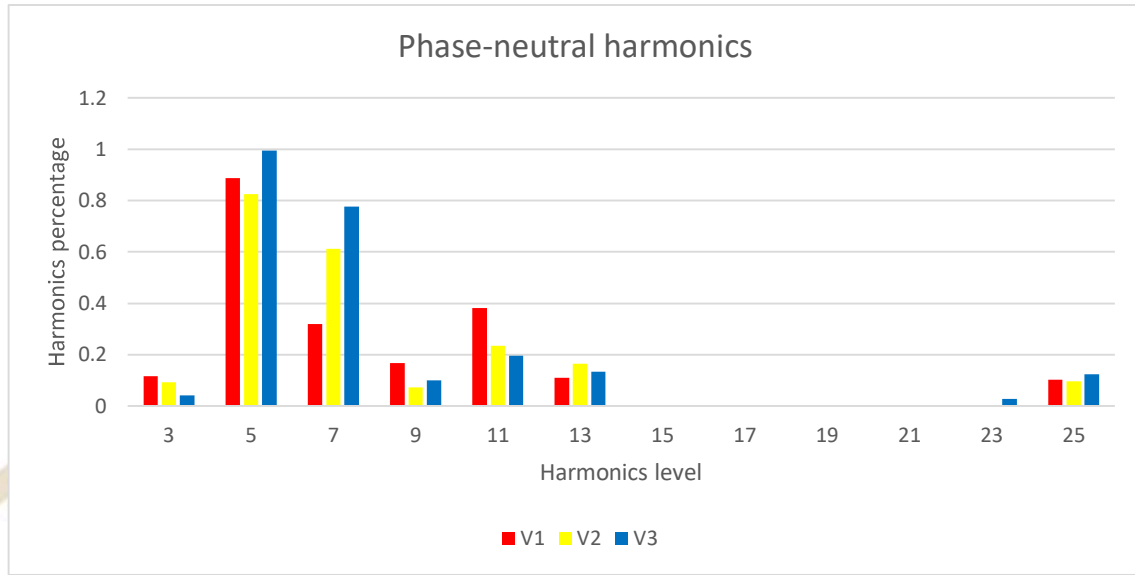

Observations:

- The total harmonic distortion and individual odd harmonics distortion – voltage is within the stipulated limit, as per IEEE STD 519-2014.

• **Current (%)**

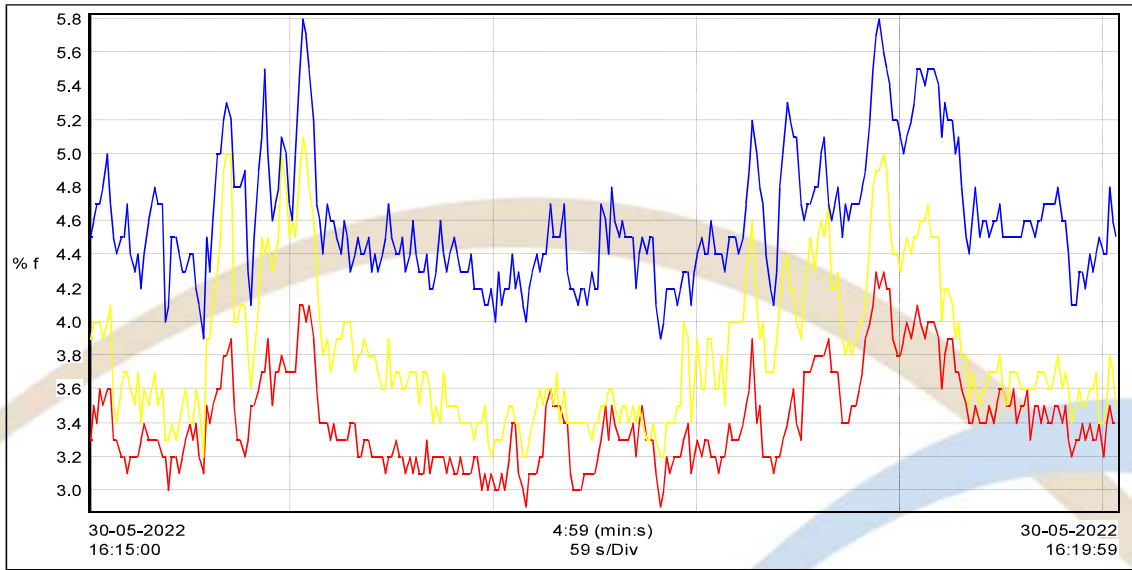

Description	Unit	Average	Min	Max
A1 THDf	% f	3.415	2.9	4.3
A2 THDf	% f	3.824	3.2	5.1
A3 THDf	% f	4.598	3.9	5.8

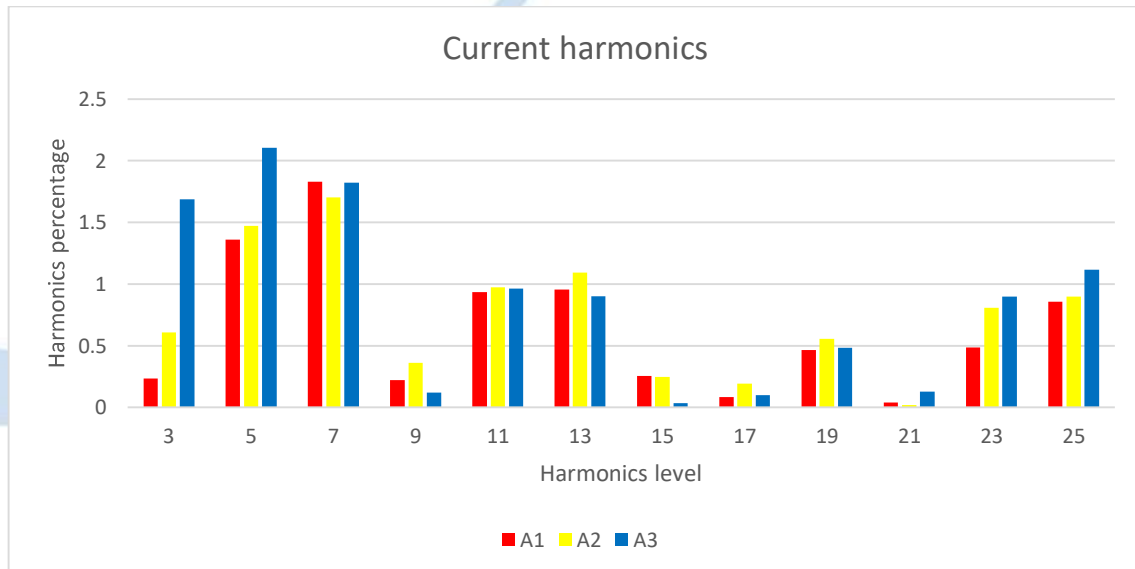

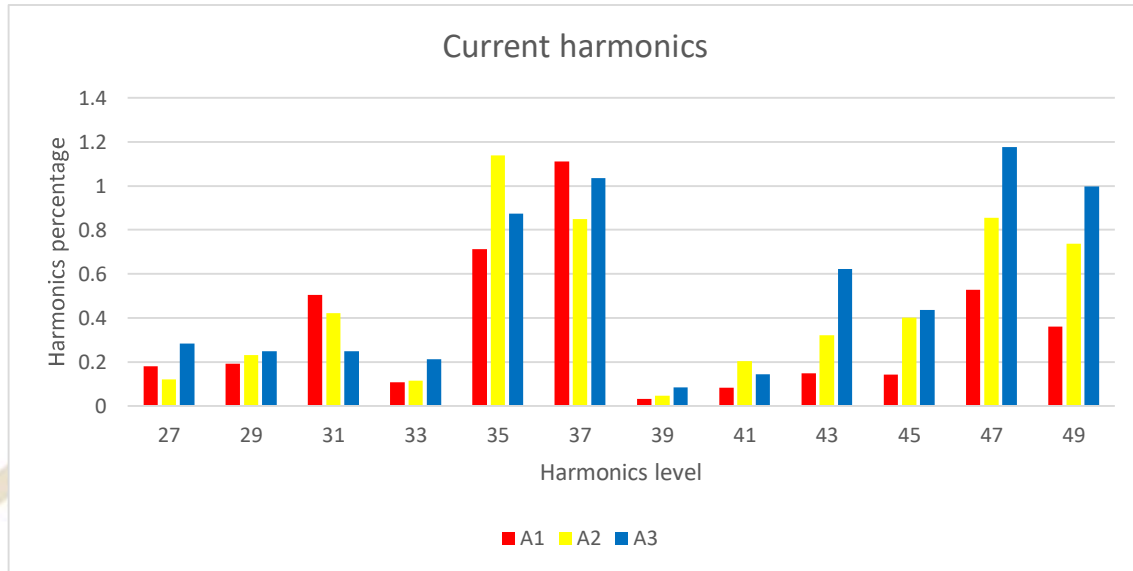

Observations:

- Here, $I_{sc}/I_L = 1000 <$
- The total harmonic distortion – current is within the stipulated limit 20%, as per IEEE STD 519-2014.
- The odd harmonic distortion – current upto the 49th order within the stipulated limit 1.4% as per IEEE STD 519-2014.

5.2.1.8 Impact of Harmonics

- **Tripping of circuit breakers and fuses:**

Due to resonance effects, the current levels may rise to multifold levels, which results in tripping of the breakers and melting fuses.

- **Impact of Harmonics on Transformers:**

The eddy current loss increases with the square of the frequency while hysteresis losses increase linearly with the frequency. Thus, losses also increase due to harmonics also leading to additional heating of the transformer.

- **Impact of Harmonics on Motors:**

The eddy current loss increases with the square of the frequency while hysteresis losses increase linearly with the frequency. Therefore, higher frequency voltage components produce additional losses in the core of AC motors, which in turn, increase the operating temperature of the core and the windings surrounding the core. Application of non-sinusoidal voltages to motors results in harmonic current circulation in the windings of motors.

Stray motor losses, which include winding eddy current losses, high frequency rotor and stator surface losses, and tooth pulsation losses, also increase due to harmonic voltages and currents

The interaction between the positive and negative sequence magnetic fields and currents produces torsional oscillations of the motor shaft. These oscillations result in shaft vibrations. If the frequency of oscillations coincides with the natural mechanical frequency of the shaft, the vibrations are amplified and severe damage to the motor shaft may occur.

- **Overloading of the capacitors:**

The capacitors are overloaded due to harmonics producing excessive heat. As the capacitive reactance decreases with the frequencies, even smaller amplitudes of the harmonic voltages result into higher currents, which are detrimental to the capacitors.

- **Losses in distribution equipment:**

Harmonics in addition to the fundamental current cause additional losses in the cables, fuses and also the bus bars.

- **Excessive currents in the neutral conductor:**

The phase currents cancel each other in neutral, and resultant neutral current is zero under balanced load conditions without harmonics. However, in a 4-wire system with single-phase non-linear loads, odd numbered multiples of the third harmonics (3rd, 9th, 15th) do not cancel, rather add together in the neutral conductor. The neutral currents may rise and there is a possibility of excessive heating of the neutral conductor.

- **Malfunctioning of the Electronic Controls and Computers:**

Electronic controls and computers rely on power quality for their reliable operation. Harmonics result into distorted waveforms, neutral currents and over voltages, which affect the performance of these gadgets.

- **Measurement errors in the metering systems:**

The accuracy of metering systems is affected by the presence of harmonics. Watt-hour meters accurately register the direction of power flow at harmonic frequencies, but they have amplitude errors, which increase with frequency.

The corrective actions may be initiated if any of the above problems are observed.

Corrective Actions:

The corrective actions involve installation of

- Installing de-tuned capacitors,
- Passive harmonic filters only,
- Active harmonic filters only,
- Passive & Active harmonic filters together.

At present the above-mentioned impacts were not observed in the premises.

5.3 Energy Conservation measures already taken and proposed for future

JNPT SEZ has reported that there are no specific energy conservation measures taken in FY20-21, however, continuous reliability and power quality of supplied power is their priority, and it serves to energy efficiency indirectly.

5.3.1 Proposed energy conservation measures

- To mitigate the harmonic in the distribution system, carry out the Power quality and harmonic study.
- It's suggested to maintain the unity power factor by installing passive filters across the substation panels.

5.4 Inclusion and Exclusions

It is to be noted that no inclusion and exclusion are made in the report data provided by JNPT SEZ during the FY20-21.

6 Energy Accounting Major Observations

The overall the T & D losses are reduced over the time interval, as increase in the operation of industries in JNPT-SEZ, the major observations are as under,

1. Referring to the BEE notification no. **No. 18/1/BEE/DISCOM/2021**, The software has not been developed to create monthly, quarterly and yearly energy accounting reports. The electricity distribution company shall establish an information technology enabled system to create energy accounting reports without any manual interference: Provided that such system may be established within a period of three years from the date of the commencement of these regulations in case of urban.
2. Till the establishment IT enabled system, the energy accounting at transformer level need to be done for evaluation of losses, i.e., Transmission & Distribution losses and

transformer losses. To evaluate the exact losses within the distribution system, the data accounting at 33kV, 11kV and Feeder wise need to be done on the propriety basis.

For the recording and monitoring of electrical power at ES1 & ES2 subs station, it is suggested to install desired size CTs at all electrical panels, in consultation with OEM.

3. At the consumer end the power factor need to be unity to optimize the distribution losses.
4. At the station level maintain the near to unity power factor to optimize the losses, i.e., at the time of annual energy audit visit the power factor at ES-2 I/C-1 is around 0.238 leading with load of 25.71kWh/ 96.06kVAh, which accounts for losses around 70kWh with unity power factor.

At present the capacitor bank is not in operation. So, it is suggested to install the passive filters in consultation with OEM, to optimize the leading power factor to near unit.

7 Annexures

7.1 Introduction of verification Firm

ENCOSYM Solutions Pvt Ltd. Defines itself as catalyst for energy conservation by combining technology, innovation and financing to assist its client in their journey from energy consumption to energy conservation and efficiency.

Till date the 50+ projects executed in the energy intensive industries & commercial building etc. The identified saving from the same projects is around 25,000 MWh which equivalent to ~2000 MTOE and around 1000 MWh savings delivered through ESCO mode.

ENCOSYM Solutions Pvt Ltd is empanelled with BUREAU OF ENERGY EFFICIENCY, Maharashtra Energy Development Agency (MEDA) with class 'A', Andhra Pradesh State Energy Efficiency Development Corporation (APSEEDCO), Petroleum Conservation and Research Association (PCRA) & SIDBI.

All the promoters with 25+ years of experience in Energy and Infrastructure Industry. In house technical team with 1200+ audit has been conducted across sector.

The Consultants team of ENCOSYM Solutions Pvt. Ltd. Was ably represented by

- Mr. Abhay Athalye - BEE Certified Energy Auditor, Director
- Mr. Bapu Amritkar - Director
- Mr. Shailesh Joshi - Director
- Mr. Atul Joshi - BEE Accredited Energy Auditor **(AEA-037)**
- Mr. Umesh Phatakare - BEE Certified Energy Manager **(EA-31077)**
- Mr. Ratnadeep Bhalerao - Sr. Engineer – Energy Audit
- Mr. Mukesh Mhasde - Engineer- Energy Audit

7.2 Minutes of meeting with DISCOM team

The representatives of M/s ENCOSYM Solution Pvt Ltd, Thane visited the JNPT-SEZ for the purpose of annual energy audit on 25th May 2022 & 30th May 2022. While all the requisite data verification has been done by the 20th June 2022.

The Field measurements and data collection work has been completed as per scope of annual energy audit for JNPT SEZ.

The observations are as mentioned below,

- verification of existing pattern of energy distribution across periphery of electricity distribution company
- verification of accounted energy flow submitted by electricity distribution company at all applicable voltage levels of the distribution network
- Verification of accounted energy consumption at consumer end.
- Measurement of Distribution transformer for accounting of losses. (7 no's)

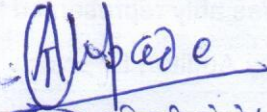

For JNPT SEZ
Mr. Anil Chopade
Mr. Milind Aigalkar
Mr. B.D. Sinkar

अनिल टी. चोपडे / ANIL T. CHOPDE
प्रबंधक (उपयोगिता सेवाएँ)
MANAGER (UTILITY SERVICES)
ज.ने.प.न्यास, शेवा, नवी मुंबई 400707
J.N.P.T., Sheva, Navi Mumbai 400707

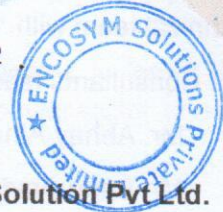
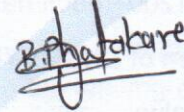

For ENCOSYM Solution Pvt Ltd.
Mr. Atul Joshi (AEA-037)
Mr. Umesh Phatakare (EA-31077)

7.3 Checklist Prepared by auditing Firm

Sr No.	Description
1	Input Electricity at 220KV
2	Data Accounting at 33kV level
3	Data Accounting at 11kV level
4	Data Accounting at 440V level
5	Feeder wise data accounting
6	Consumer wise Data Accounting
7	Status of Multifunction meter at Substation
8	IT system status
9	Transformer losses calculations based on loading
10	Evaluation of Distribution Line losses and Service Connection Losses
11	Data Extraction from consumer meter Manual or Software based

7.4 Scope of Work and Methodology Objective

- To undertake an energy audit to identify areas for energy, balancing and optimization

Scope

- verification of existing pattern of energy distribution across periphery of electricity distribution company
- verification of accounted energy flow submitted by electricity distribution company at all applicable voltage levels of the distribution network
 - energy flow between transmission and 33kV/11kV incoming distribution feeders,
 - energy flow between 33kV outgoing and 11kV incoming feeders,
 - energy flow between 11 kV feeders and distribution transformers, or high voltage distribution system,
 - energy flow between distribution transformer, or high voltage distribution system to end consumer, including ring main system,
 - energy flow between Feeder to end-consumer; and
 - energy flow between 11 kV directly to consumer

Methodology

- Energy Audit was carried out as per the methodology, which is schematically presented below,

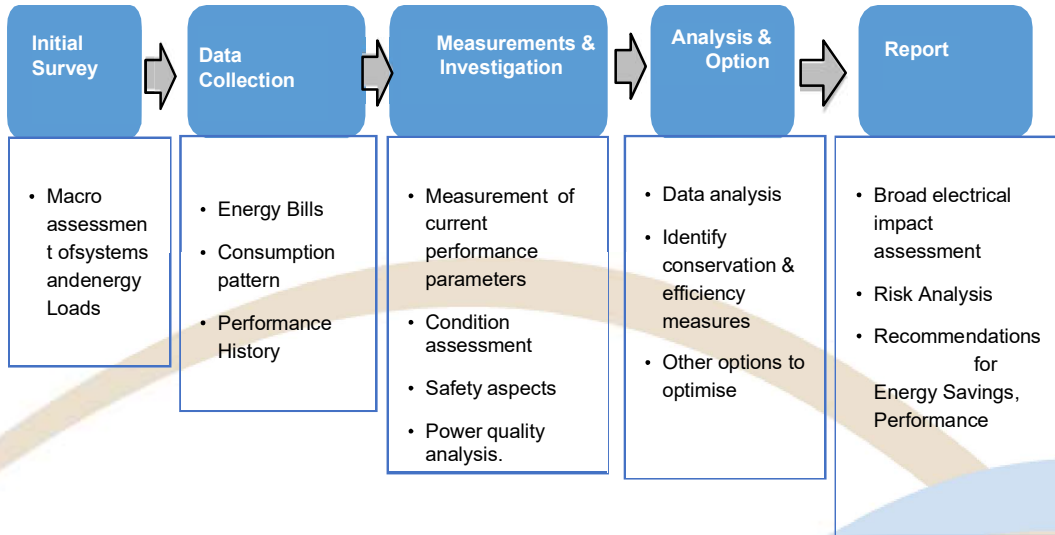

- The audit is carried out as per the guidelines of Bureau of Energy Efficiency (BEE), Government of India and by Accredited Energy Auditor.
- The auditor carried his own instruments and equipment for carrying out the measurements and investigations.

Instruments:

- The list of instruments is as under,

Sr No	Name of the instrument	Make	Model
1	Portable Load Analyzer	Krykard	ALM-31

7.5 Infrastructure details

Form-Details of Input Infrastructure					
1	Parameters	Total	Covered during in audit	Verified by Auditor in Sample Check	Remarks (Source of data)
i	Number of circles	NA			
ii	Number of divisions	NA			
iii	Number of sub-divisions	NA			
iv	Number of feeders	11			
v	Number of DTs	5			
vi	Number of consumers	13			
2	Parameters	66kV and above	33kV	11/22kV	LT
a. i.	Number of conventional metered consumers	0	0	0	0
ii	Number of consumers with 'smart' meters	0	0	5	8
iii	Number of consumers with 'smart prepaid' meters	0	0	0	0
iv	Number of consumers with 'AMR' meters	0	0	0	0
v	Number of consumers with 'non-smart prepaid' meters	0	0	0	0

vi	Number of unmetered consumers	0	0	0	0	0	
vii	Number of total consumers	0	0	0	5	8	
b.i.	Number of conventionally metered Distribution Transformers	0	0	0	0	4	
ii	Number of DTs with communicable meters	0	0	0	0	0	
iii	Number of unmetered DTs	0	0	0	0	1	
iv	Number of total Transformers	0	0	0	0	5	
c.i.	Number of metered feeders	0	1	10	10	0	
ii	Number of feeders with communicable meters	0	0	0	0	0	
iii	Number of unmetered feeders	0	0	0	0	0	
iv	Number of total feeders	0	1	10	10	0	
d.	Line length (ct km)						
e.	Length of Aerial Bunched Cables						
f.	Length of Underground Cables						22Km
3	Voltage level	Particulars	MU	Reference	Remarks (Source of data)		
i	66kV and above	Long-Term Conventional		Includes input energy for franchisees			
		Medium Conventional					
		Short Term Conventional	0.72			MSLDC	
		Banking					



	Long-Term Renewable energy				
	Medium and Short-Term RE				
	Captive, open access input				Includes power from bilateral/ PX/ DEEP
	Sale of surplus power				Any power wheeled for any purchase other than sale to DISCOM. Does not include input for franchisee.
	Quantum of inter-state transmission loss				As confirmed by SLDC, RLDC etc
	Power procured from inter-state sources		1		Based on data from Form 5
	Power at state transmission boundary		1		
	Long-Term Conventional				
	Medium Conventional				
	Short Term Conventional				
	Banking				
	Long-Term Renewable energy				
	Medium and Short-Term RE				
	Captive, open access input				
	Sale of surplus power				
	Quantum of intra-state transmission loss		0		
	Power procured from intra-state sources		0		
ii	33kV				
iii					
iv	33 kV				
	Renewable Energy Procurement				



		Small capacity conventional/ biomass/ hydro plants Procurement			
		Captive, open access input			
v	11 kV	Renewable Energy Procurement			
		Small capacity conventional/ biomass/ hydro plants Procurement			
		Sales Migration Input			
vi	LT	Renewable Energy Procurement			
		Sales Migration Input			
vii		Energy Embedded within DISCOM wires network	0		
viii		Total Energy Available/ Input	1		
4	Voltage level	Energy Sales Particulars	MU	Reference	
		DISCOM' consumers	0	Include sales to consumers in franchisee areas, unmetered consumers	
		Demand from open access, captive		Non DISCOM's sales	
i	LT Level	Embedded generation used at LT level		Demand from embedded generation at LT level	
		Sale at LT level	0		
		Quantum of LT level losses	0		
		Energy input at LT level			Reading not available

ii	DISCOM' consumers	0	Include sales to consumers in franchisee areas, unmetered consumers	
	Demand from open access, captive		Non DISCOM's sales	
	Embedded generation at 11 kV level used		Demand from embedded generation at 11kV level	
	Sales at 11 kV level	0		
	Quantum of Losses at 11 kV	0		
iii	Energy input at 11 kV level			Reading not available
	DISCOM' consumers	0	Include sales to consumers in franchisee areas, unmetered consumers	
	Demand from open access, captive		Non DISCOM's sales	
	Embedded generation at 33 kV or below level		This is DISCOM and OA demand met via energy generated at same voltage level	
	Sales at 33 kV level	0		
iv	Quantum of Losses at 33 kV	0		
	Energy input at 33kV Level			
	DISCOM' consumers	0	Include sales to consumers in franchisee areas, unmetered consumers	
	Demand from open access, captive		Non DISCOM's sales	
	Cross border sale of energy			



ENCOSYM

Annual Energy Audit Report
M/s JNPT-SEZ

Ref: ENCOSYM_EA/FY23_001
Date: June 29, 2022

	Sale to other DISCOMs			
	Banking			
	Energy input at > 33kV Level	1		
	Sales at 66kV and above (EHV)	0		
	Total Energy Requirement	1		
	Total Energy Sales	1		

- **Main Sub-station Panels:**



- **E1 & E2 Substation**



7.6 Electrical Distribution System

- 220kV/33kV Substation

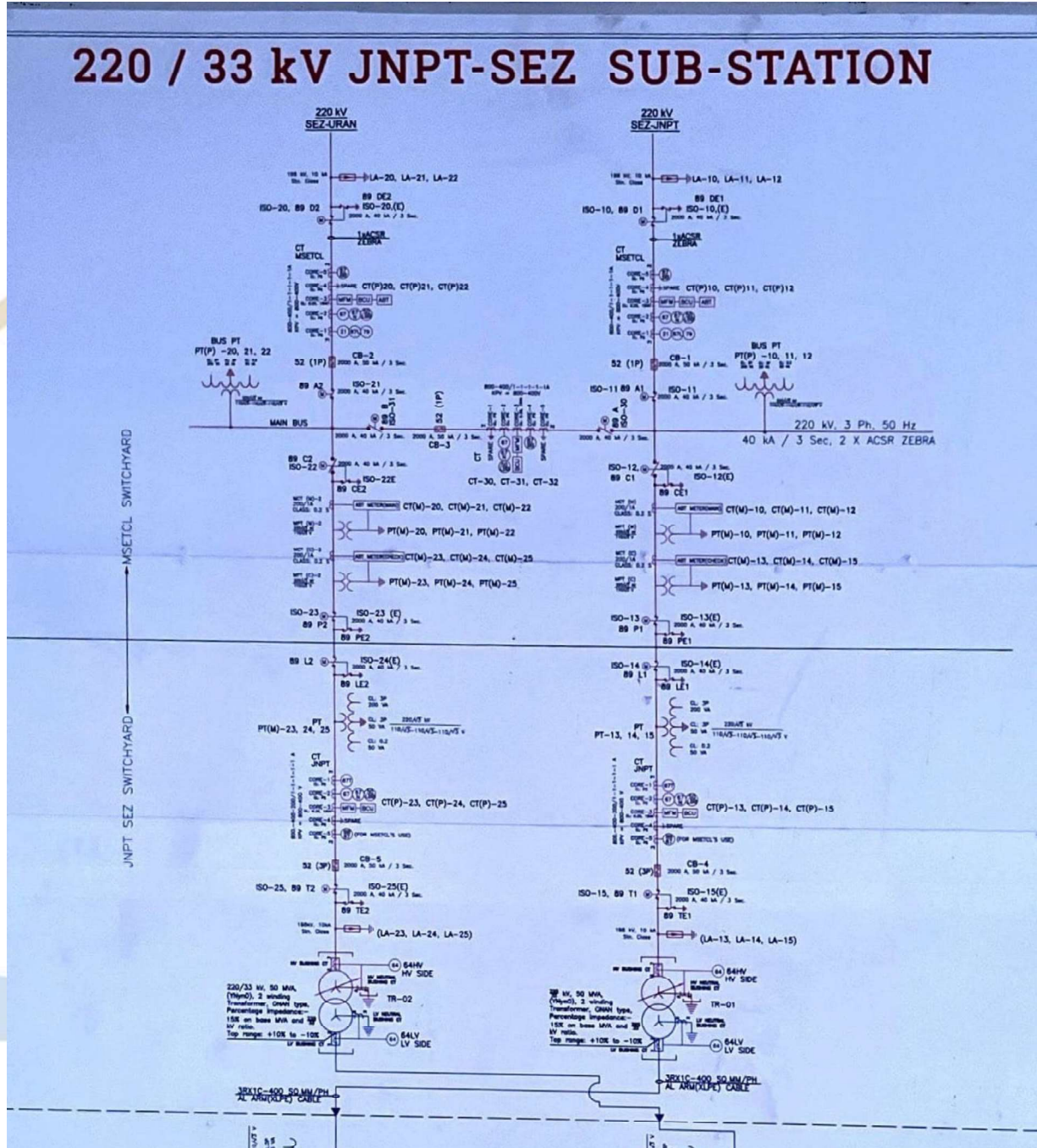



Ref: ENCOSYM_EA/FY23_001
Date: June 29, 2022

Annual Energy Audit Report
M/s JNPT-SEZ

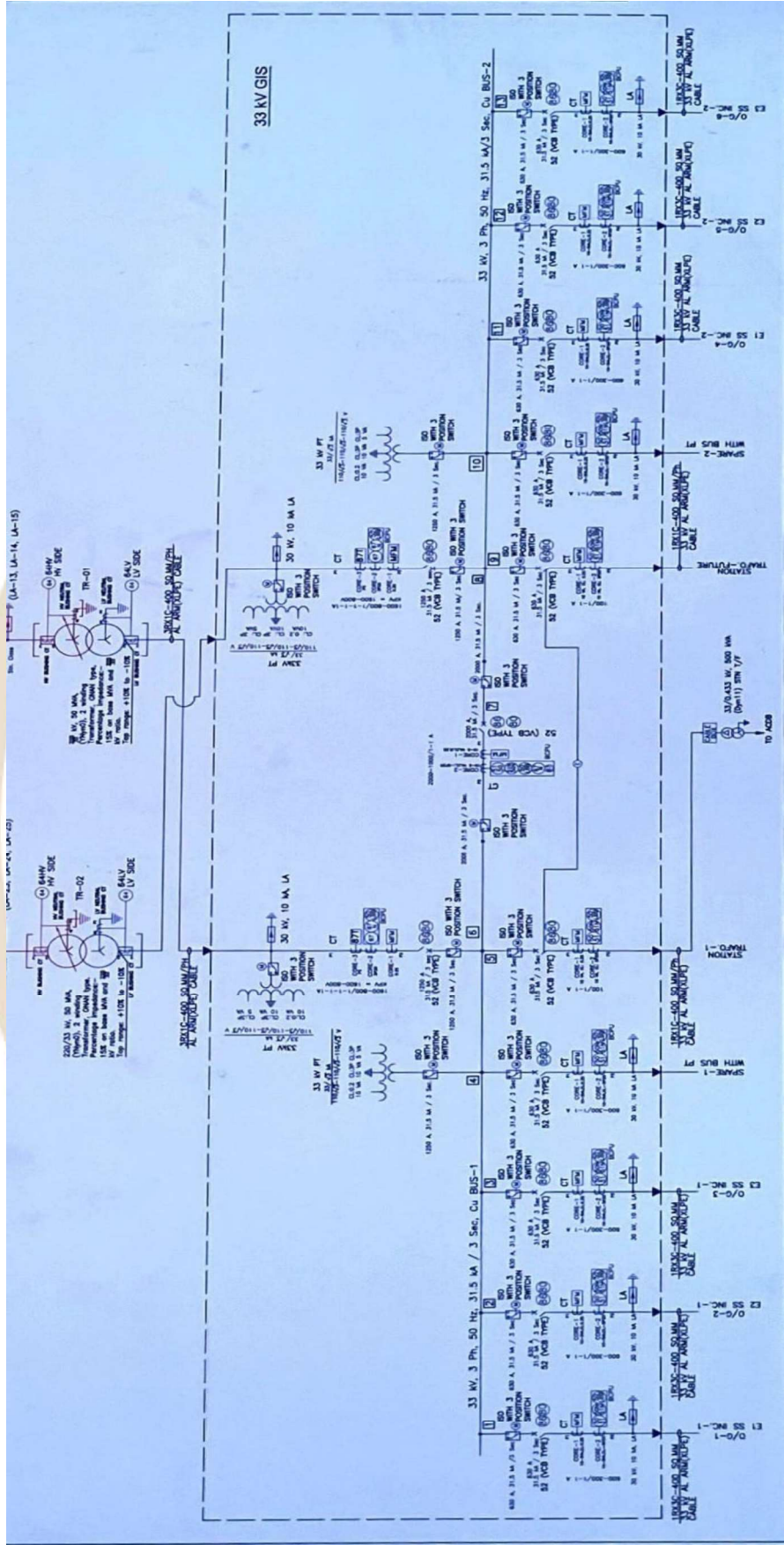

• E1 Sub Station

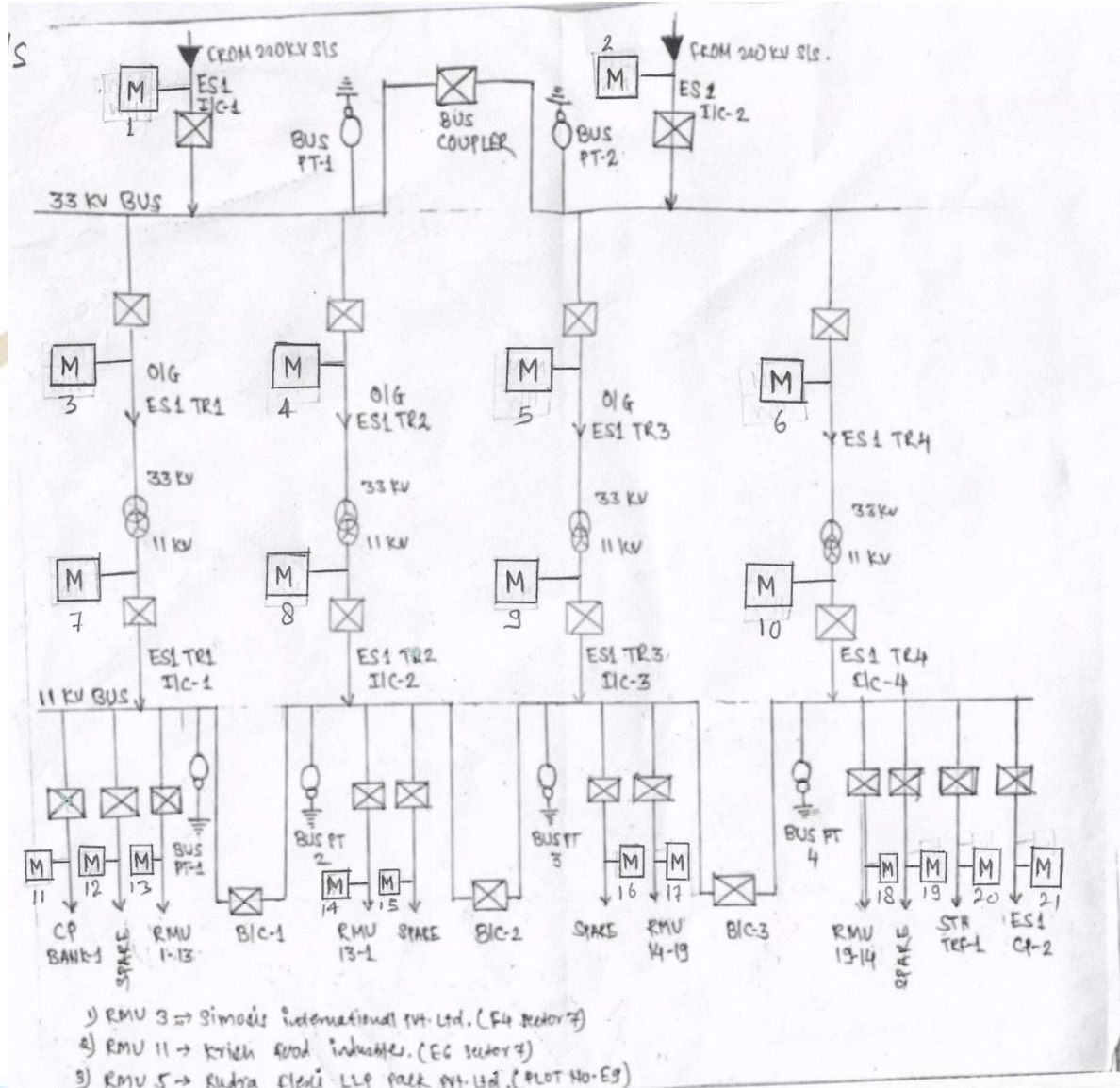

• E2 Sub Station

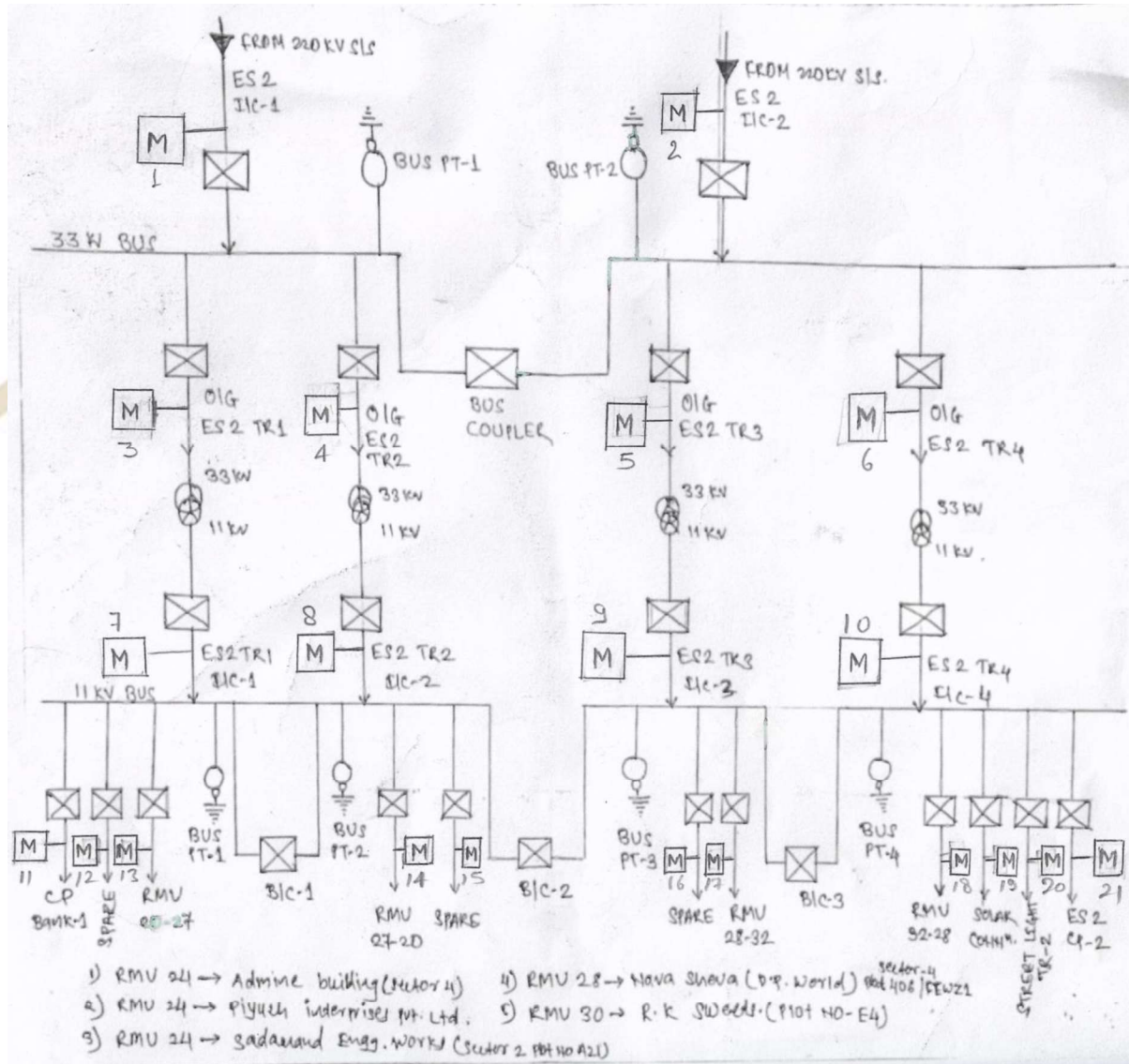

• **Block Diagram -RMU Distribution**

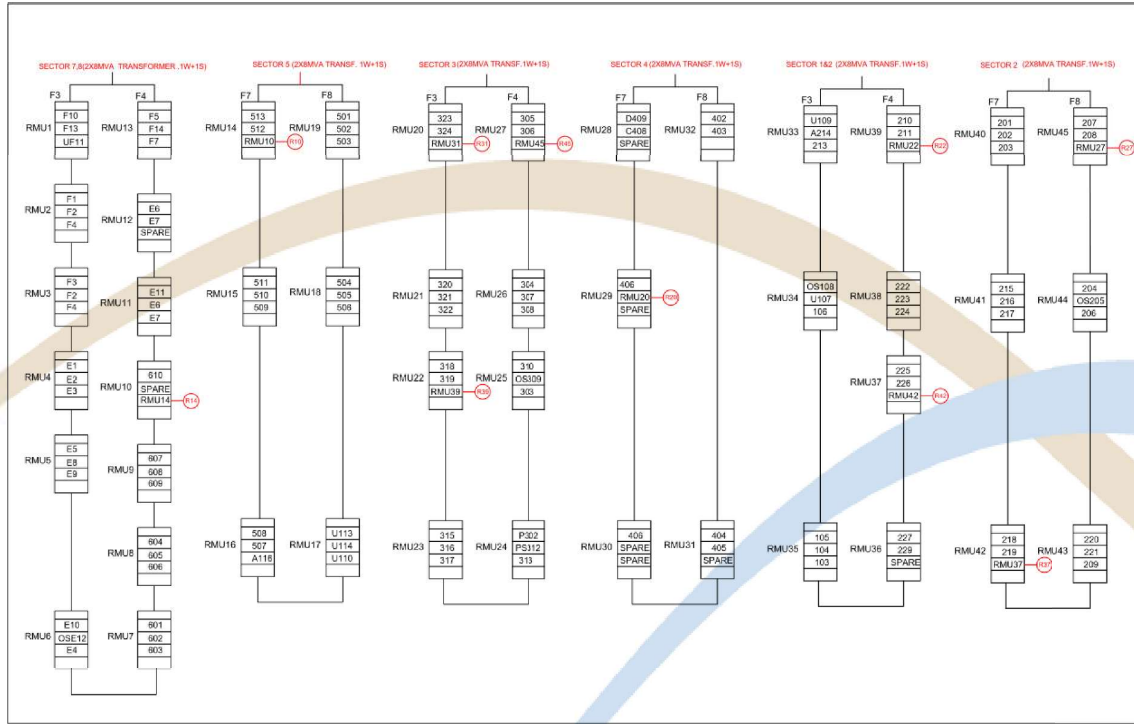

NOTE: **R19** THIS SYMBOL IN GENERAL INDICATES THAT ONE OUTGOING FEEDER OF RMU NO. 9 IS CONNECTED TO RMU NO. 19 TO FORM RING MAIN THIS IS APPLICABLE FOR OTHER RMU'S ALSO

Note: Transformer details are provided in section 4.3

7.7 Power Purchase Details

The power purchase details are as under,

Month	Schedule (kWh)	Actual (kWh)	Deviation (kWh)
Aug-21	176400	99552	-76848
Sep-21	432000	117569	-314431
Oct-21	232848	143957	-88891
Nov-21	277963	155865	-122098
Dec-21	284581	204699	-79882
Jan-22	259704	225382	-34322
Feb-22	259704	225382	-34322
Mar-22	318522	286102	-32420

7.8 Category of service details

The consumer details with category are as under,

Consumer Name	Type of Consumer	Category	Supply Voltage
M/s Simosis International	HT	Industrial	11kV
M/s Krish Food Industry (India)	HT	Industrial	11kV
M/s Rudra Flexipack LLP	HT	Industrial	11kV
M/s Sadanand Engineering Works	LT	Commercial	440V
M/s Piyush Enterprises	LT	Commercial	440V
Admin Building	LT	Utility	440V
Streetlight	LT	Utility	440V
M/s Nhava Sheva Business Parks Pvt Ltd	HT	Commercial	11kV
M/s R K Sweets Mars Pvt Ltd	HT	Industrial	11kV
Streetlight	LT	Utility	440V
Station Transformer-01	LT	Utility	440V
M/s Sarveshwar Logistics Services Pvt Ltd	LT	Commercial	440V
Station Transformer- 500kVA	LT	Utility	440V

7.9 List of documents verified with each parameter

- DSM Report & Energy accounting for electricity input at 220kV level from datasheet.
- Energy accounting from electricity bills of consumers.
- Transformer test certificates for -no load and full load losses.
- SLD for present electrical distribution system.

7.10 List of parameters arrived through calculation

List of Parameters arrives through calculations	Source documents
Actual Transformer Losses	Transformer Test Certificates
	Actual loading of transformer from annual data accounting
Transmission, Distribution Lines and service connection losses	Transmission losses till 220kv supply -by MERC standards
	Electricity Input at 220KV - All Transformer Losses- Electricity consumption at consumer end)
	Datasheets of Consumer Electricity Bill accounting & electricity input at 220KV
	Electricity Bill

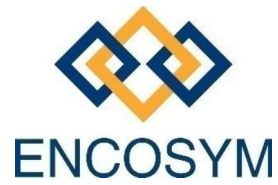

ENCOSYM Solutions Private Limited

603, 6thFloor, Oriana Business Park,

Plot no. 69-70, Road No.22,

Wagle Industrial Estate

Thane (West) 400604, INDIA

www.encosym.com
